

FEATURE

- Low C_{iss}
- Fast switching
- 100% avalanche tested
- Improved dv/dt capability

Maximum output current

$$I_{OM}: 0.5 \text{ A}$$

Output voltage

$$V_O: 6\text{V}$$

Continuous total dissipation

$$P_D: 1.25 \text{ W}$$

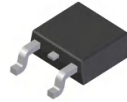

ABSOLUTE MAXIMUM RATINGS (Operating temperature range applies unless otherwise specified)

Parameter	Symbol	Value	Unit
Input Voltage	V_i	25	V
Operating Junction Temperature Range	T_{OPR}	0-+125	°C
Storage Temperature Range	T_{STG}	-65-+150	°C

ELECTRICAL CHARACTERISTICS AT SPECIFIED VIRTUAL JUNCTION TEMPERATURE

Parameter	Symbol	Test conditions	Min	Typ	Max	Unit
Output Voltage	V_o	25°C	5.75	6	6.25	V
		$8\text{V} \leq V_i \leq 21\text{V}, I_o = 5\text{mA} - 350\text{mA}$ $P_o \leq 15\text{W}$	0-125°C	5.7	6	6.3
Load Regulation	ΔV_o	$I_o = 5\text{mA} - 0.5\text{A}$	25°C	18	120	mV
		$I_o = 5\text{mA} - 200\text{mA}$	25°C	10	60	mV
Line Regulation	ΔV_o	$8\text{V} \leq V_i \leq 25\text{V}, I_o = 200\text{mA}$	25°C	5	100	mV
		$9\text{V} \leq V_i \leq 25\text{V}, I_o = 200\text{mA}$	25°C	1.5	50	mV
Quiescent Current	I_q	25°C		4.3	6	mA
Quiescent Current Change	ΔI_q	$9\text{V} \leq V_i \leq 25\text{V}, I_o = 200\text{mA}$	0-125°C		0.8	mA
		$5\text{mA} \leq I_o \leq 350\text{mA}$	0-125°C		0.5	mA
Output Noise Voltage	V_N	$10\text{Hz} \leq f \leq 100\text{KHz}$	25°C	45		uV
Ripple Rejection	RR	$9\text{V} \leq V_i \leq 19\text{V}, f = 120\text{Hz}, I_o = 300\text{mA}$	0-125°C	59	80	dB
Dropout Voltage	V_d	$I_o = 350\text{mA}$	25°C	2		V
Short Circuit Current	I_{sc}	$V_i = 11\text{V}$	25°C	270		mA
Peak Current	I_{pk}	25°C		0.5		A

TYPICAL APPLICATION

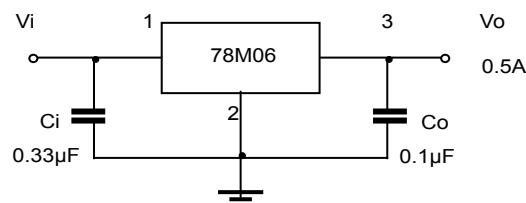

RATING AND CHARACTERISTIC CURVES

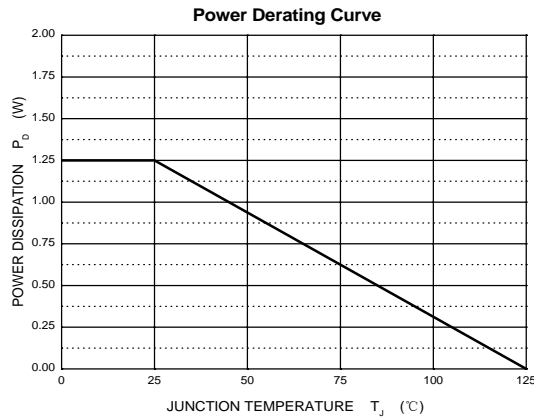
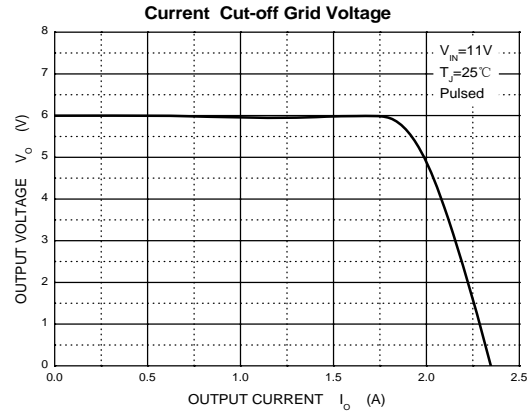
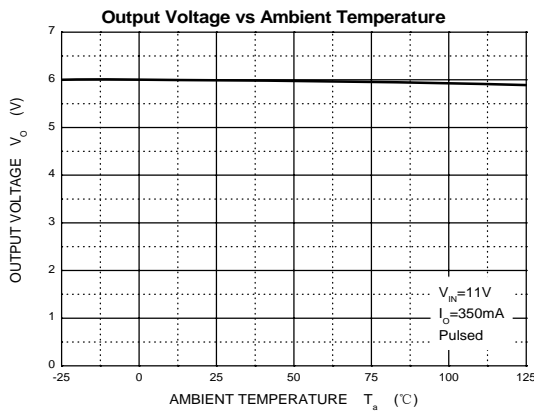
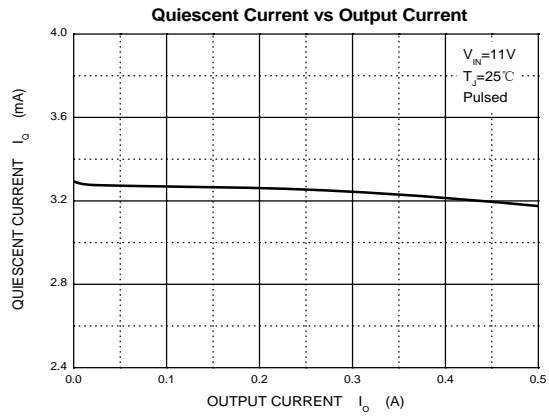
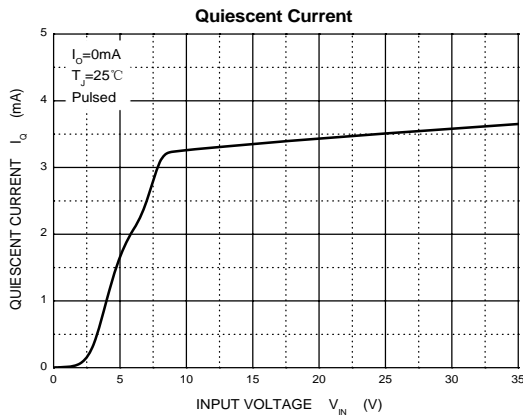
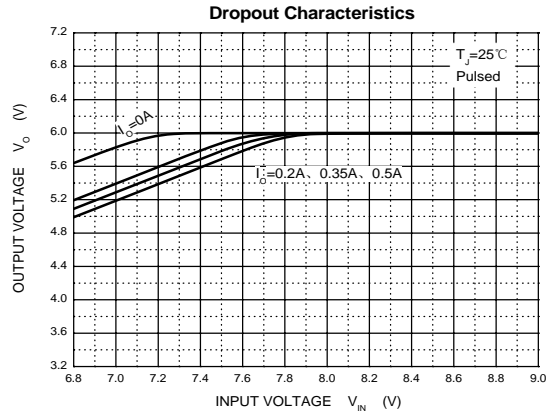
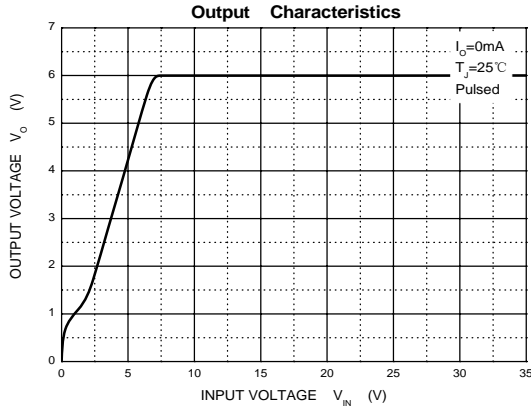

Soldering parameters

Reflow Condition		Pb-Free assembly (see as below)
Pre Heat	-Temperature Min ($T_{s(min)}$)	+150 °C
	-Temperature Max ($T_{s(max)}$)	+200 °C
	-Time (Min to Max) (ts)	60-180 secs.
Average ramp up rate (Liquid us Temp (T_L) to peak)		3 °C/sec. Max
$T_{s(max)}$ to T_L - Ramp-up Rate		3 °C/sec. Max
Reflow	-Temperature (T_L) (Liquid us)	+217 °C
	-Temperature (t_L)	60-150 secs.
Peak Temp (T_P)		+260(+0/-5) °C
Time within 5 °C of actual Peak Temp (t_p)		30 secs. Max
Ramp-down Rate		6 °C/sec. Max
Time 25 °C to Peak Temp (T_P)		8 min. Max
Do not exceed		+260 °C



Package Dimensions & Suggested Pad Layout

TO-252

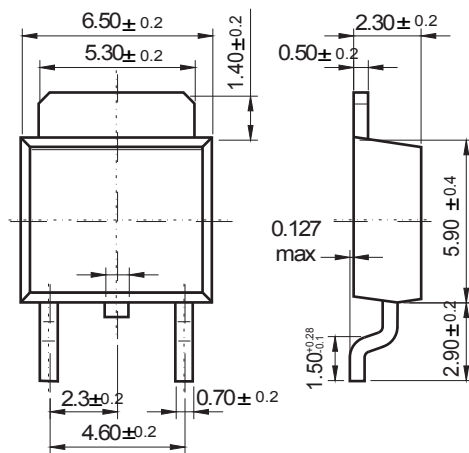

Dimensions in inches and (millimeters)

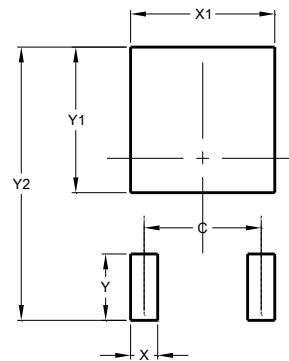

Dimensions	Value (in mm)
C	4.55
X	1.50
X1	5.80
Y	2.70
Y1	6.00
Y2	10.90

Tape & reel specification

Tape		Symbol	Dimension (mm)
		P0	4.00±0.20
		P1	8.00±0.20
		P2	2.00±0.20
		D0	1.55±0.15
		D1	1.55±0.20
		E	1.75±0.20
		F	7.50±0.20
		W	16.00±0.20
		A0	7.10±0.20
		B0	10.50±0.20
		K0	2.70±0.20
		T	0.30±0.10
		D2	330.0±5.0
		D3	100.0±4.0
W1	20.0±5.0		
W2	25.0±5.0		
I	13.0±2.0		
Quantity: 2500PCS			

13" Reel

