

## DESCRIPTION

The AO3401A is the high cell density trenched P-ch MOSFETs, which provides excellent R<sub>DS(ON)</sub> and efficiency for most of the small power switching and load switch applications.

The AO3401A meet the RoHS and Green Product requirement with full function reliability approved.

## FEATURES

- Green Device Available
- Super Low Gate Charge
- Excellent CdV/dt effect decline
- Advanced high cell density Trench technology

$V_{DSS}$  -30 V  
 $I_D$  -4.2A  
 $R_{DS(ON)}$  42 m  $\Omega$

X1DV

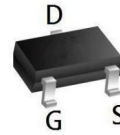

SOT23-3L top view

### Equivalent Circuit

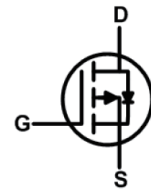

## MAXIMUM RATINGS AND ELECTRICAL CHARACTERISTICS

### Absolute Maximum Ratings

| Symbol                       | Parameter                            | Rating     | Units            |
|------------------------------|--------------------------------------|------------|------------------|
| $V_{DS}$                     | Drain-Source Voltage                 | -30        | V                |
| $V_{GS}$                     | Gate-Source Voltage                  | $\pm 12$   | V                |
| $I_D @ T_A=25^\circ\text{C}$ | Continuous Drain Current             | -4.2       | A                |
| $I_D @ T_A=70^\circ\text{C}$ | Continuous Drain Current             | -3.6       | A                |
| $I_{DM}$                     | Pulsed Drain Current <sup>2</sup>    | -16        | A                |
| $P_D @ T_A=25^\circ\text{C}$ | Total Power Dissipation <sup>3</sup> | 1.4        | W                |
| $P_D @ T_A=70^\circ\text{C}$ | Total Power Dissipation <sup>3</sup> | 0.9        | W                |
| $T_{STG}$                    | Storage Temperature Range            | -55 to 150 | $^\circ\text{C}$ |
| $T_J$                        | Operating Junction Temperature Range | -55 to 150 | $^\circ\text{C}$ |

### Thermal Data

| Symbol          | Parameter  | Typ. | Max. | Unit               |
|-----------------|--|------|------|--------------------|
| $R_{\theta JA}$ | Thermal Resistance Junction-Ambient <sup>1</sup>                 | ---  | 105  | $^\circ\text{C/W}$ |
| $R_{\theta JA}$ | Thermal Resistance Junction-Ambient <sup>1</sup> (t $\leq 10$ s) | ---  | ---  | $^\circ\text{C/W}$ |

**Electrical Characteristics**  $T_J=25^\circ\text{C}$  unless otherwise noted

| Parameter                                    | Symbol        | Test Conditions   | Min. | Typ. | Max.      | Unit       |
|--|---------------|---|------|------|-----------|------------|
| <b>Static Characteristics</b>                |               |   |      |      |           |            |
| Drain-Source Breakdown Voltage               | $V_{(BR)DSS}$ | $V_{GS} = 0V, I_D = -250\mu A$                                      | -30  | -    | -         | V          |
| Zero Gate Voltage Drain Current              | $I_{DSS}$     | $V_{DS} = -30V, V_{GS} = 0V$  | -    | -    | -1        | $\mu A$    |
| Gate-Body Leakage Current                    | $I_{GSS}$     | $V_{DS} = 0V, V_{GS} = \pm 12V$                                     | -    | -    | $\pm 100$ | nA         |
| Gate-Threshold Voltage                       | $V_{GS(th)}$  | $V_{DS} = V_{GS}, I_D = -250\mu A$                                  | -0.7 | -1   | -1.3      | V          |
| Drain-Source on-Resistance <sup>3</sup>      | $R_{DS(on)}$  | $V_{GS} = -10V, I_D = -4.2A$  | -    | 42   | 60        | m $\Omega$ |
|  |               | $V_{GS} = -4.5V, I_D = -4A$   | -    | 51   | 75        |            |
|  |               | $V_{GS} = -2.5V, I_D = -1A$   | -    | 60   | 90        |            |
| <b>Dynamic Characteristics<sup>4</sup></b>   |               |   |      |      |           |            |
| Input Capacitance                            | $C_{iss}$     | $V_{DS} = -15V, V_{GS} = 0V,$<br>$f = 1MHz$                         | -    | 745  | -         | pF         |
| Output Capacitance                           | $C_{oss}$     |   | -    | 70   | -         |            |
| Reverse Transfer Capacitance                 | $C_{rss}$     |   | -    | 57   | -         |            |
| <b>Switching Characteristics<sup>4</sup></b> |               |   |      |      |           |            |
| Total Gate Charge                            | $Q_g$         | $V_{GS} = -4.5V, V_{DS} = -15V,$<br>$I_D = -4.2A$                   | -    | 8    | -         | nC         |
| Gate-Source Charge                           | $Q_{gs}$      |   | -    | 1.8  | -         |            |
| Gate-Drain Charge                            | $Q_{gd}$      |   | -    | 2.7  | -         |            |
| Turn-on Delay Time                           | $t_{d(on)}$   | $V_{GS} = -10V, V_{DD} = -15V,$<br>$I_D = -4.2A, R_{GEN} = 6\Omega$ | -    | 7    | -         | ns         |
| Rise Time                                    | $t_r$         |   | -    | 3    | -         |            |
| Turn-off Delay Time                          | $t_{d(off)}$  |   | -    | 30   | -         |            |
| Fall Time                                    | $t_f$         |   | -    | 12   | -         |            |
| <b>Drain-Source Diode Characteristics</b>    |               |   |      |      |           |            |
| Diode Forward Voltage <sup>3</sup>           | $V_{SD}$      | $I_S = -4.2A, V_{GS} = 0V$  | -    | -    | -1.2      | V          |
| Continuous Source Current                    | $I_S$         |   | -    | -    | -4.2      | A          |

**Notes:**

1. Repetitive rating, pulse width limited by junction temperature  $T_{J(MAX)}=150^\circ\text{C}$
2. The data tested by surface mounted on a 1 inch<sup>2</sup> FR-4 board with 2OZ copper, The value in any given application depends on the user's specific board design.
3. Pulse Test: Pulse width $\leq 300\mu s$ , duty cycle $\leq 2\%$ .
4. This value is guaranteed by design hence it is not included in the production test.

RATING AND CHARACTERISTIC CURVES

Output Characteristics

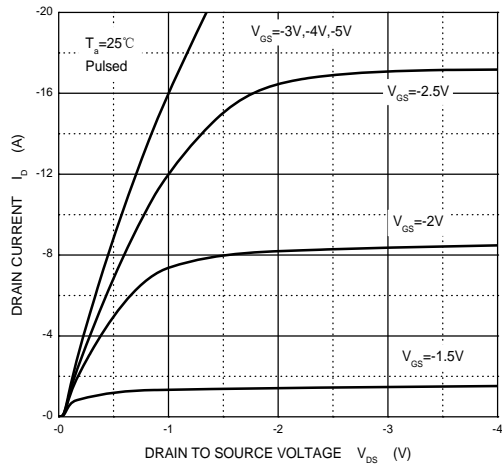

Transfer Characteristics

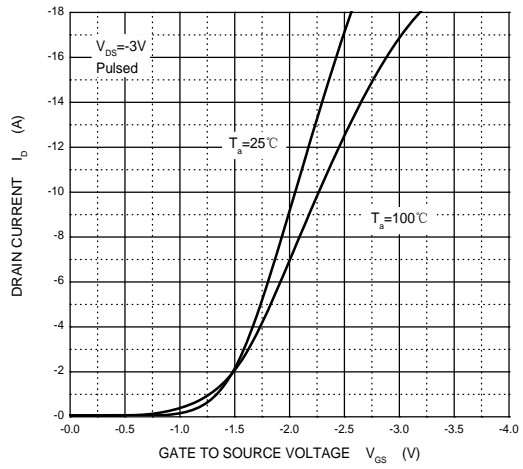

$R_{DS(ON)}$  —  $I_D$

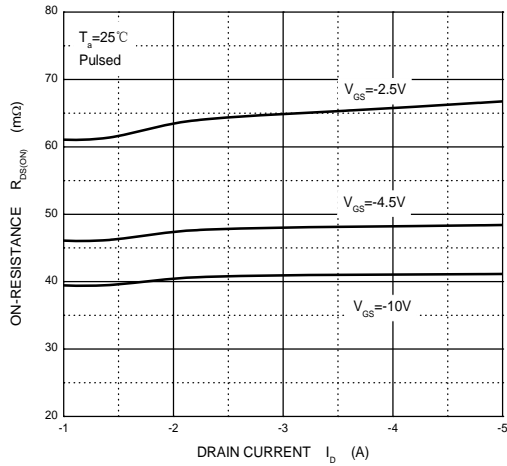

$R_{DS(ON)}$  —  $V_{GS}$

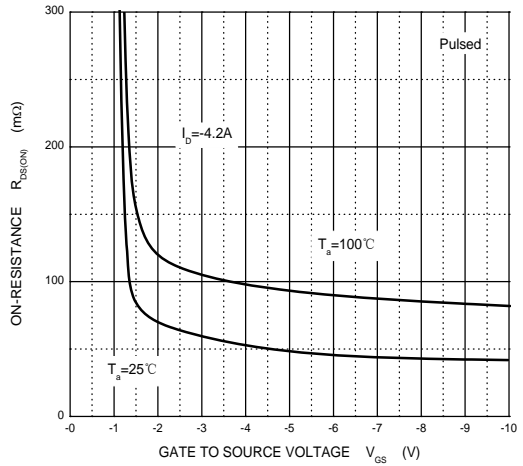

$I_S$  —  $V_{SD}$

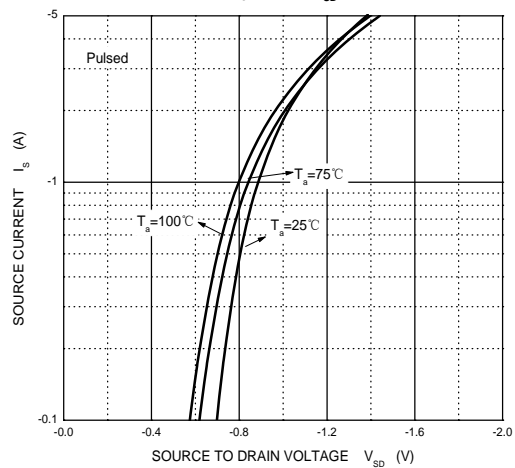

Threshold Voltage

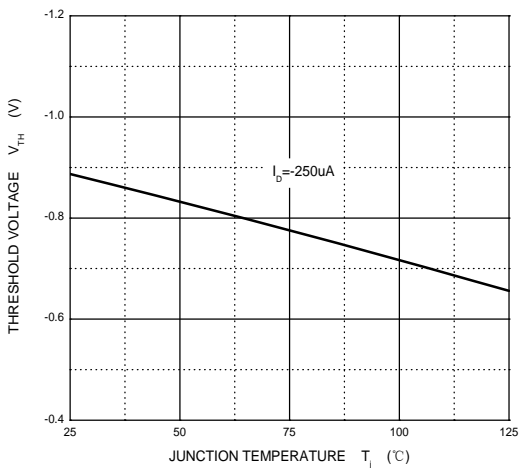

Soldering parameters

| Reflow Condition  |                                    | Pb-Free assembly<br>(see as below) |
|---|------------------------------------|------------------------------------|
| Pre Heat  | -Temperature Min ( $T_{s(min)}$ )  | +150 °C                            |
|   | -Temperature Max ( $T_{s(max)}$ )  | +200 °C                            |
|   | -Time (Min to Max) (ts)            | 60-180 secs.                       |
| Average ramp up rate (Liquid us Temp ( $T_L$ ) to peak) |                                    | 3 °C/sec. Max                      |
| $T_{s(max)}$ to $T_L$ - Ramp-up Rate                    |                                    | 3 °C/sec. Max                      |
| Reflow  | -Temperature ( $T_L$ ) (Liquid us) | +217 °C                            |
|   | -Temperature ( $t_L$ )             | 60-150 secs.                       |
| Peak Temp ( $T_P$ )                                     |                                    | +260(+0/-5) °C                     |
| Time within 5 °C of actual Peak Temp ( $t_p$ )          |                                    | 30 secs. Max                       |
| Ramp-down Rate  |                                    | 6 °C/sec. Max                      |
| Time 25 °C to Peak Temp ( $T_P$ )                       |                                    | 8 min. Max                         |
| Do not exceed   |                                    | +260 °C                            |



Package Dimensions & Suggested Pad Layout

SOT23-3L

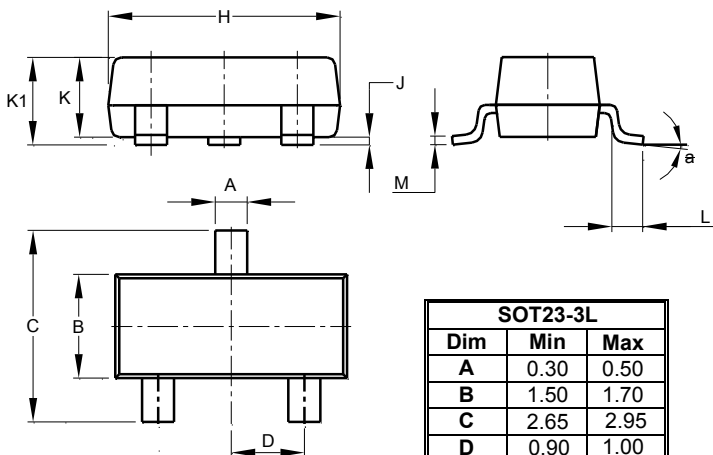

| SOT23-3L             |      |      |
|----------------------|------|------|
| Dim                  | Min  | Max  |
| A                    | 0.30 | 0.50 |
| B                    | 1.50 | 1.70 |
| C                    | 2.65 | 2.95 |
| D                    | 0.90 | 1.00 |
| H                    | 2.82 | 3.02 |
| J                    |      | 0.10 |
| K                    | 1.05 | 1.15 |
| K1                   | 1.05 | 1.25 |
| L                    | 0.30 | 0.60 |
| M                    | 0.10 | 0.20 |
| a                    | 0°   | 8°   |
| All Dimensions in mm |      |      |

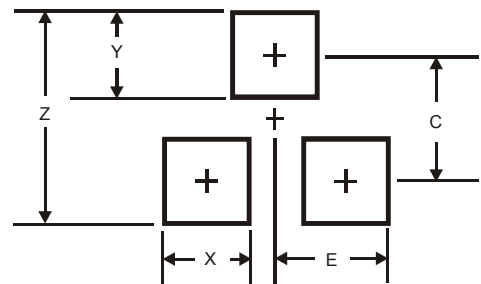

| Dimensions | SOT23-3L |
|------------|----------|
| Z          | 3.3      |
| X          | 0.9      |
| Y          | 1.0      |
| C          | 2.3      |
| E          | 1.40     |

Tape & reel specification

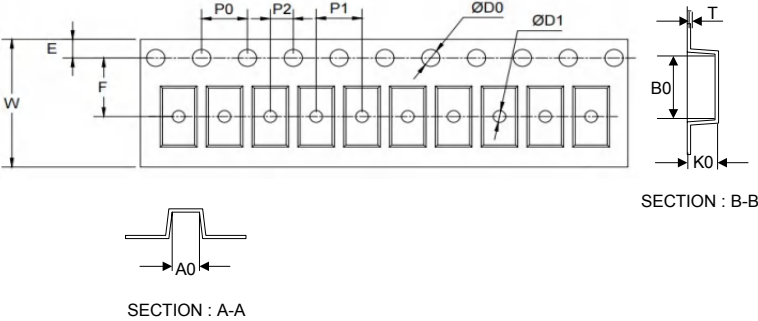
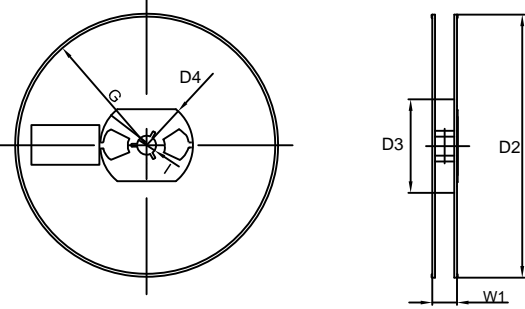
| Tape  | Symbol   | Dimension (mm) |           |
|---|--|----------------|-----------|
|  | P0   | 4.00±0.20      |           |
|   | P1   | 4.00±0.20      |           |
|   | P2   | 2.00±0.20      |           |
|   | D0   | 1.55±0.20      |           |
|   | D1   | 1.05±0.20      |           |
|   | E  | 1.55±0.20      |           |
|   | F  | 3.60±0.20      |           |
|   | W  | 8.00±0.20      |           |
|   | A0   | 3.80±0.20      |           |
|   | B0   | 3.50±0.20      |           |
|   | K0   | 1.55±0.20      |           |
|   | T  | 0.25±0.15      |           |
|   | <p>7" Reel</p>  | D2             | 178.0±5.0 |
|   |  | D3             | 55Min.    |
|   |  | D4             | R24.0±3.0 |
|   |  | G              | R82.0±3.0 |
| I   |  | 13.0±2.0       |           |
| W1  |  | 11.0±3.0       |           |
| Quantity: 3000PCS   |  |                |           |