

General Description

The ESD5Z6.0 Series is designed to protect voltage sensitive components from ESD and transient voltage events. Excellent clamping capability, low leakage, and fast response time, make these parts ideal for ESD protection on designs where board space is at a premium.

Features

Small Body Outline Dimensions
 Low Body Height
 Stand-off Voltage: 6.0 V
 Peak Power up to 200 Watts @ 8 x 20 μ s Pulse
 Low Leakage
 Response Time is Typically < 1 ns
 ESD Rating of Class 3 (> 16 kV) per Human Body Model
 IEC61000-4-2 Level 4 ESD Protection
 IEC61000-4-4 Level 4 EFT Protection
 We declare that the material of product compliance with RoHS requirements.
 S-Prefix for Automotive and Other Applications Requiring Unique Site and Control Change Requirements; AEC-Q101 Qualified and PPAP Capable.

Applications

Cellular phones
 Portable devices
 Digital cameras
 Power supplies

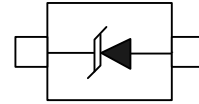

Schematic & PIN Configuration

Absolute Maximum Rating

Symbol	Parameter	Value	Units	
P_{PP}	Peak Pulse Power ($t_p = 8/20\mu s$)	100	W	
T_L	Maximum lead temperature for soldering during 10s	260	$^{\circ}C$	
T_{stg}	Storage Temperature Range	-55 to +150	$^{\circ}C$	
T_{op}	Operating Temperature Range	-40 to +125	$^{\circ}C$	
T_j	Maximum junction temperature	150	$^{\circ}C$	
	IEC61000-4-2 (ESD)	air discharge contact discharge	± 15 ± 8	KV
	IEC61000-4-4 (EFT)		40	A
	ESD Voltage	Per Human Body Model	16	KV

Electrical Characteristics

Device	Device Marking	V_{RWM} (V)	I_R (uA) @ V_{RWM}	V_{BR} (V) @ I_T (Note 1)	I_T	V_{BR} (V) @ I_T (Note 1)	V_C (V) @ Max I_{PP}^*	I_{PP} (A)*	P_{PK} (W)*	C (pF)
		Max	Max	Min	mA	Max	Max	Max	Max	Typ
ESD5Z6.0	ZG	6.0	1	7.5	1	8.5	18.8	5.8	100	47

*Surge current waveform per Figure 1.

- V_{BR} is measured with a pulse test current I_T at an ambient temperature of 25°C.

Electronics Parameter

Symbol	Parameter
I_{PP}	Maximum Reverse Peak Pulse Current
V_C	Clamping Voltage @ I_{PP}
V_{RWM}	Working Peak Reverse Voltage
I_R	Maximum Reverse Leakage Current @ V_{RWM}
I_T	Test Current
V_{BR}	Breakdown Voltage @ I_T
I_F	Forward Current
V_F	Forward Voltage @ I_F

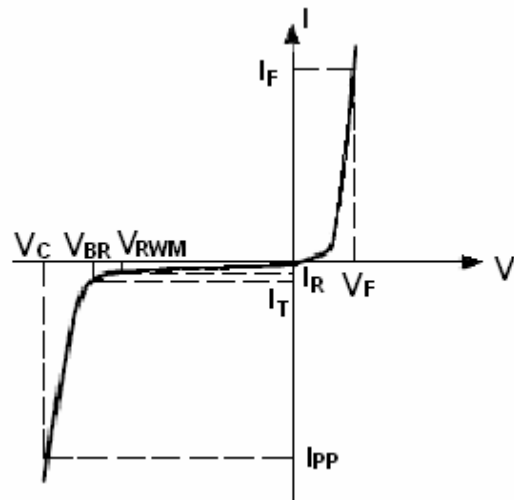

RATING AND CHARACTERISTIC CURVES

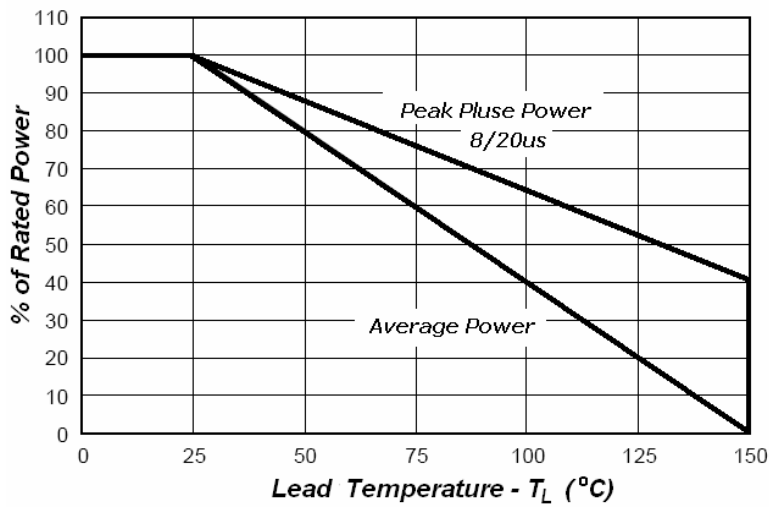
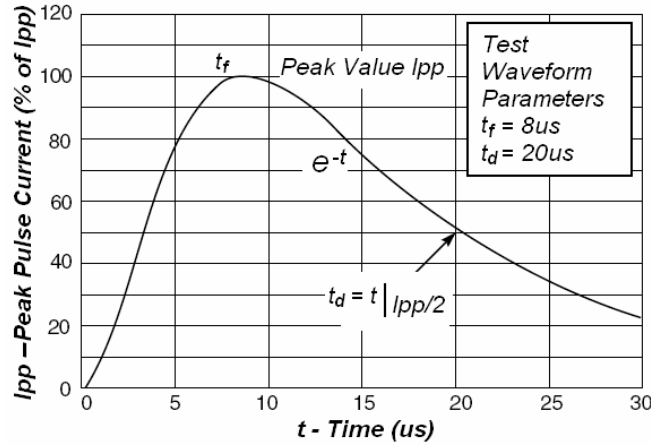

Soldering parameters

Reflow Condition		Pb-Free assembly (see as below)
Pre Heat	-Temperature Min ($T_{s(min)}$)	+150°C
	-Temperature Max($T_{s(max)}$)	+200°C
	-Time (Min to Max) (ts)	60-180 secs.
Average ramp up rate (Liquid us Temp (T_L) to peak)		3°C/sec. Max
$T_{s(max)}$ to T_L - Ramp-up Rate		3°C/sec. Max
Reflow	-Temperature(T_L)(Liquid us)	+217°C
	-Temperature(t_L)	60-150 secs.
Peak Temp (T_P)		+260(+0/-5)°C
Time within 5°C of actual Peak Temp (t_p)		30 secs. Max
Ramp-down Rate		6°C/sec. Max
Time 25°C to Peak Temp (T_P)		8 min. Max
Do not exceed		+260°C



Package Dimensions & Suggested Pad Layout

SOD523

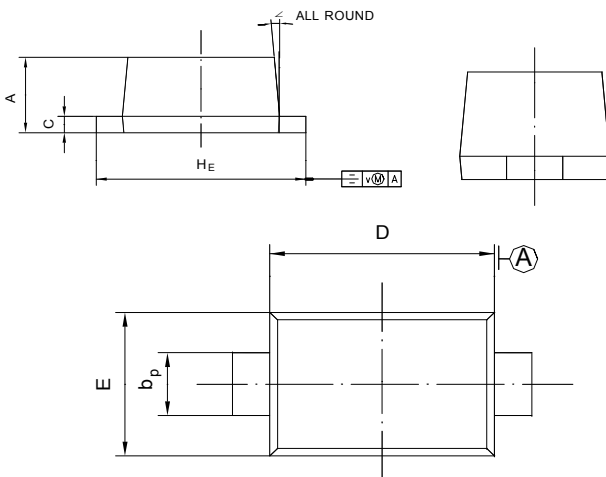

UNIT	A	b _p	C	D	E	H _E	V	∠
mm	0.70 0.50	0.40 0.20	0.14 0.05	1.30 1.10	0.90 0.75	1.70 1.50	0.1	5°

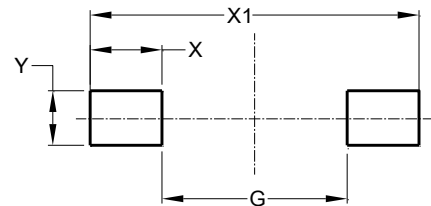

Dimensions	Value (in mm)
G	0.85
X	0.70
X1	2.25
Y	0.80

Tape & reel specification

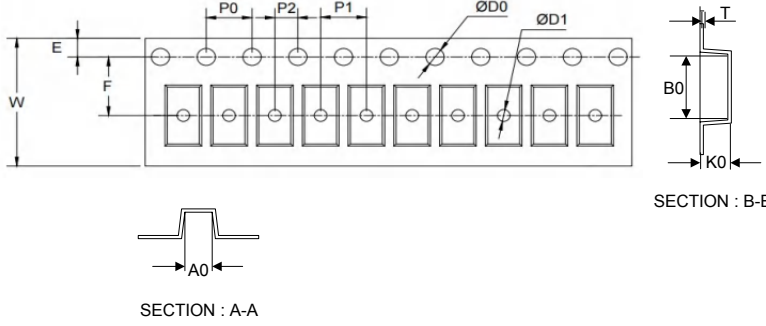
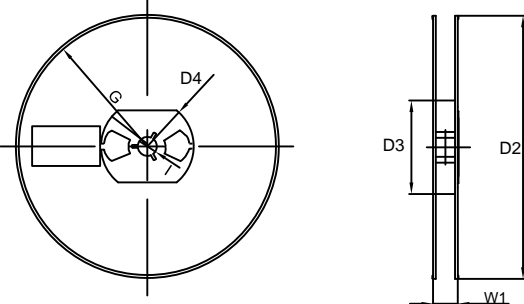
Tape	Symbol	Dimension (mm)	
	P0	4.00±0.20	
	P1	2.00±0.20	
	P2	2.00±0.20	
	D0	1.55±0.20	
	D1	0.50±0.20	
	E	1.55±0.25	
	F	3.60±0.20	
	W	8.00±0.20	
	A0	1.30±0.20	
	B0	2.35±0.20	
	K0	0.95±0.20	
	T	0.20±0.20	
	<p>7" Reel</p> 	D2	177.0±5.0
		D3	55Min.
		D4	R24.6±2.0
G		R82.0±2.0	
I		13.0±2.0	
W1		10.20±3.0	
Quantity: 3000PCS			