

$V_{DSS}$  30 V  
 $I_D$  60 A  
 $R_{DS(ON)}$  7 m $\Omega$

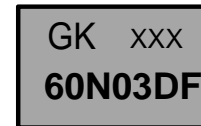
### Description

The 60N03DF is the high cell density trenched N-ch MOSFETs, which provide excellent R<sub>DS(ON)</sub> and gate charge for most of the synchronous buck converter applications.

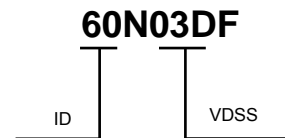
The 60N03DF meet the RoHS and Green Product requirement, 100% EAS guaranteed with full function reliability approved.

### Features

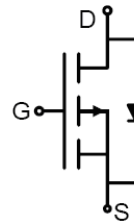
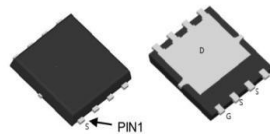
Super Low Gate Charge  
100% EAS Guaranteed  
Green Device Available  
Excellent CdV/dt effect decline  
Advanced high cell density Trench technology



LOGO **GK XXX** CODE



PDFN3X3-8L top&bottom view Equivalent Circuit



## MAXIMUM RATINGS AND ELECTRICAL CHARACTERISTICS

**Absolute Maximum Ratings** (@ T<sub>C</sub> = 25°C unless otherwise specified)

Symbol	Parameter	Rating		Units
		10s	Steady State	
V <sub>DS</sub>	Drain-Source Voltage	30		V
V <sub>GS</sub>	Gate-Source Voltage	±20		V
I <sub>D</sub> @T <sub>C</sub> =25°C	Continuous Drain Current, V <sub>GS</sub> @ 10V <sup>1</sup>	60		A
I <sub>D</sub> @T <sub>C</sub> =100°C	Continuous Drain Current, V <sub>GS</sub> @ 10V <sup>1</sup>	33		A
I <sub>DM</sub>	Pulsed Drain Current <sup>2</sup>	198		A
EAS	Single Pulse Avalanche Energy <sup>3</sup>	36		mJ
I <sub>AS</sub>	Avalanche Current	53.8		A
P <sub>D</sub> @T <sub>C</sub> =25°C	Total Power Dissipation <sup>4</sup>	32.5		W
T <sub>STG</sub>	Storage Temperature Range	-55 to 175		°C
T <sub>J</sub>	Operating Junction Temperature Range	-55 to 175		°C

### Thermal Data

Symbol	Parameter	Typ.	Max.	Unit
R <sub>θJC</sub>	Thermal Resistance Junction-Case <sup>1</sup>	---	3.56	°C/W

## Electrical Characteristics ( $T_J=25^{\circ}\text{C}$ unless otherwise noted)

Symbol	Parameter	Test Condition	Min.	Typ.	Max.	Units
<b>Off Characteristic</b>						
$V_{(BR)DSS}$	Drain-Source Breakdown Voltage	$V_{GS}=0V, I_D=250\mu A$	30	-	-	V
$I_{DSS}$	Zero Gate Voltage Drain Current	$V_{DS}=30V, V_{GS}=0V,$	-	-	1.0	$\mu A$
$I_{GSS}$	Gate to Body Leakage Current	$V_{DS}=0V, V_{GS}=\pm 20V$	-	-	$\pm 100$	nA
<b>On Characteristics</b>						
$V_{GS(th)}$	Gate Threshold Voltage	$V_{DS}=V_{GS}, I_D=250\mu A$	1.0	1.5	2.5	V
$R_{DS(on)}$	Static Drain-Source on-Resistance <small>note3</small>	$V_{GS}=10V, I_D=25A$	-	7	8	m $\Omega$
		$V_{GS}=4.5V, I_D=15A$	-	10	14	
<b>Dynamic Characteristics</b>						
$C_{iss}$	Input Capacitance	$V_{DS}=15V, V_{GS}=0V,$ $f=1.0MHz$	-	1140	-	pF
$C_{oss}$	Output Capacitance		-	175	-	pF
$C_{rss}$	Reverse Transfer Capacitance		-	151	-	pF
$Q_g$	Total Gate Charge	$V_{DS}=15V, I_D=25A,$ $V_{GS}=10V$	-	13.3	-	nC
$Q_{gs}$	Gate-Source Charge		-	3.1	-	nC
$Q_{gd}$	Gate-Drain("Miller") Charge		-	5	-	nC
<b>Switching Characteristics</b>						
$t_{d(on)}$	Turn-on Delay Time	$V_{DS}=15V,$ $I_D=25A, R_{GEN}=3\Omega,$ $V_{GS}=10V$	-	15	-	ns
$t_r$	Turn-on Rise Time		-	19	-	ns
$t_{d(off)}$	Turn-off Delay Time		-	35	-	ns
$t_f$	Turn-off Fall Time		-	21	-	ns
<b>Drain-Source Diode Characteristics and Maximum Ratings</b>						
$I_S$	Maximum Continuous Drain to Source Diode Forward Current		-	-	50	A
$I_{SM}$	Maximum Pulsed Drain to Source Diode Forward Current		-	-	200	A
$V_{SD}$	Drain to Source Diode Forward Voltage	$V_{GS}=0V, I_S=30A$	-	-	1.2	V
$t_{rr}$	Body Diode Reverse Recovery Time	$I_F=30A, dI/dt=100A/\mu s$	-	25	-	ns
$Q_{rr}$	Body Diode Reverse Recovery Charge		-	26	-	nC

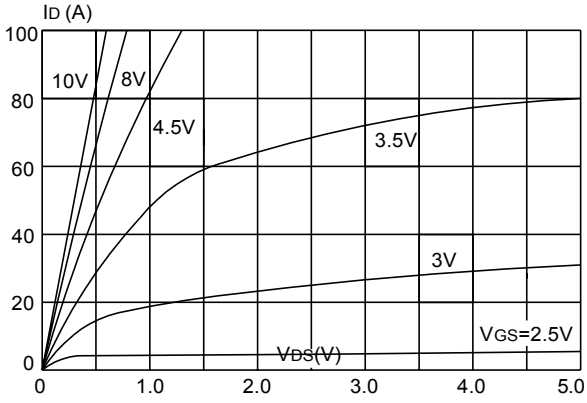
Notes: 1. Repetitive Rating: Pulse Width Limited by Maximum Junction Temperature

2. EAS condition:  $T_J=25^{\circ}\text{C}$ ,  $V_{DD}=15V$ ,  $V_G=10V$ ,  $R_G=25\Omega$ ,  $L=0.5mH$ ,  $I_{AS}=12A$

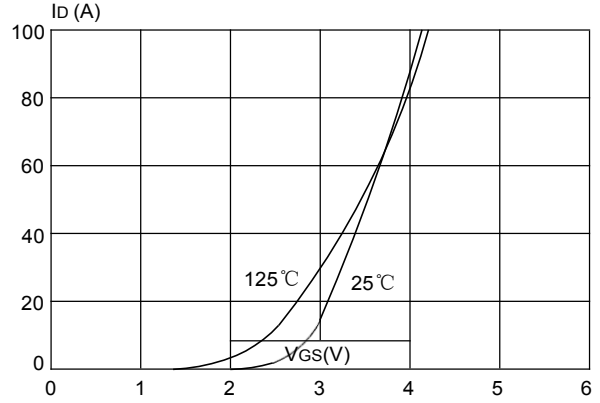
3. Pulse Test: Pulse Width $\leq 300\mu s$ , Duty Cycle $\leq 0.5\%$

**RATING AND CHARACTERISTIC CURVES**

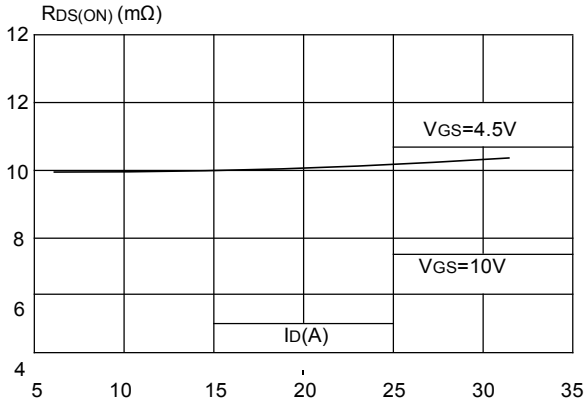
**Figure 1: Output Characteristics**



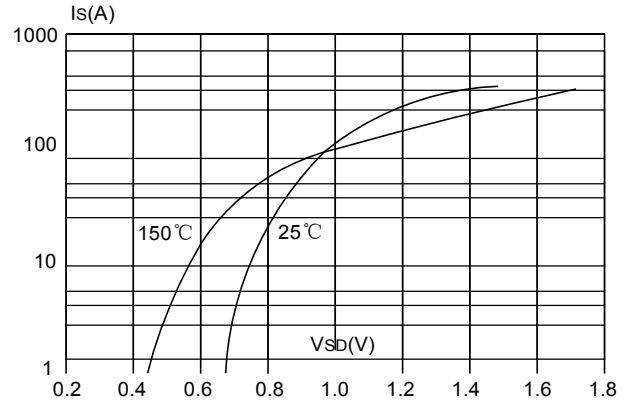
**Figure 2: Typical Transfer Characteristics**



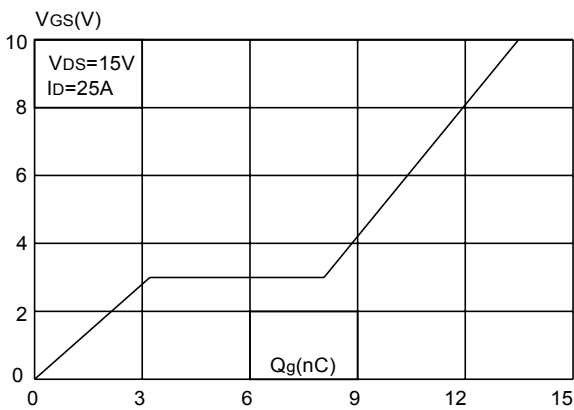
**Figure 3: On-resistance vs. Drain Current**



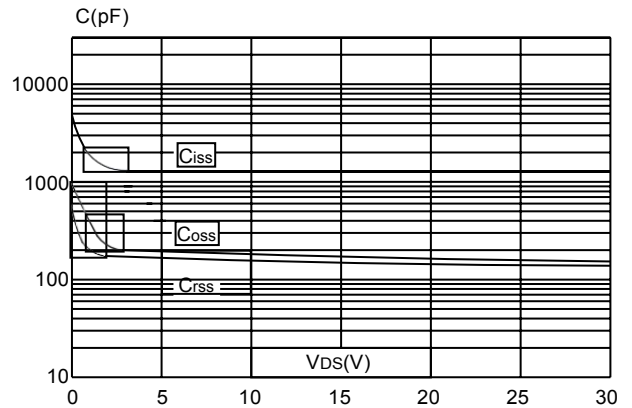
**Figure 4: Body Diode Characteristics**



**Figure 5: Gate Charge Characteristics**

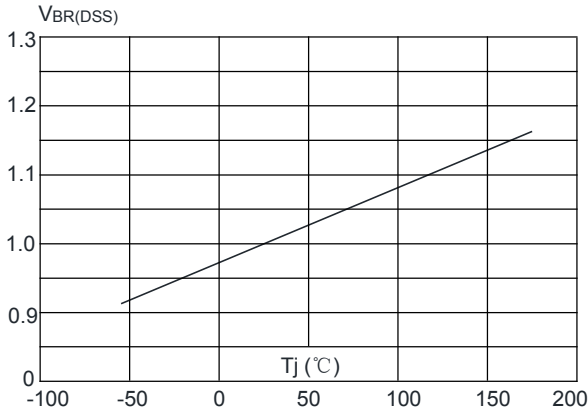


**Figure 6: Capacitance Characteristics**

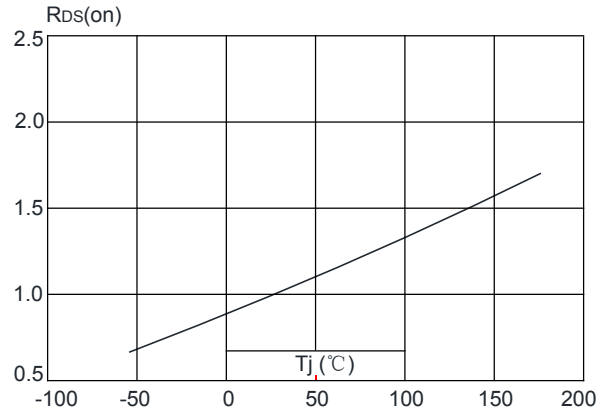


**RATING AND CHARACTERISTIC CURVES**

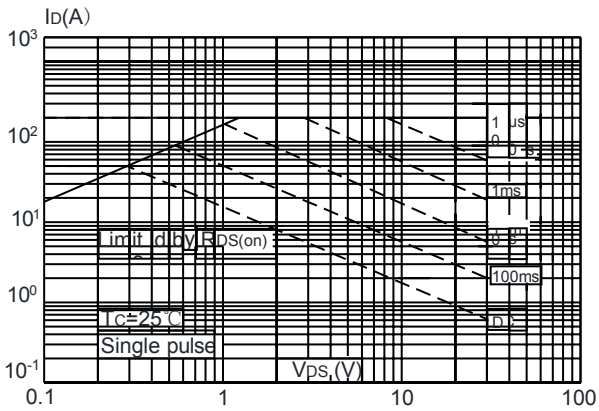
**Figure 7: Normalized Breakdown Voltage vs. Junction Temperature**



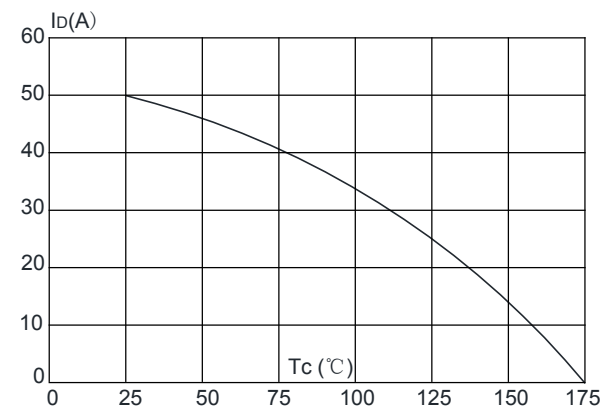
**Figure 8: Normalized on Resistance vs. Junction Temperature**



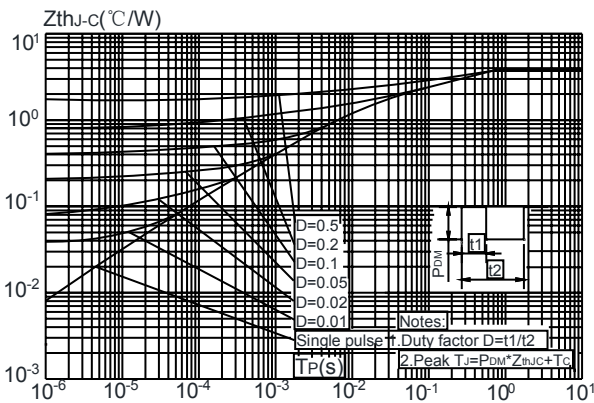
**Figure 9: Maximum Safe Operating Area**



**Figure 10: Maximum Continuous Drain Current vs. Case Temperature**



**Maximum Effective Transient Thermal Impedance, Junction-to-Case**



TEST CIRCUIT

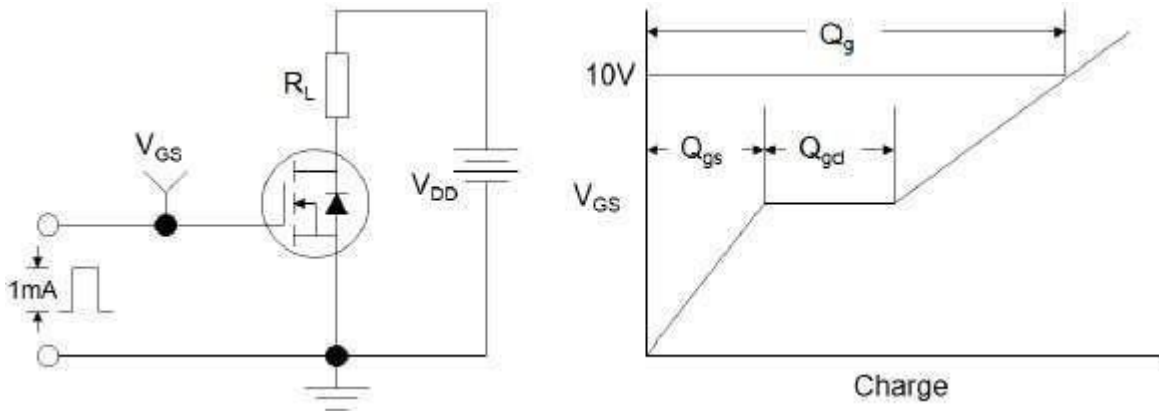


Figure1:Gate Charge Test Circuit & Waveform

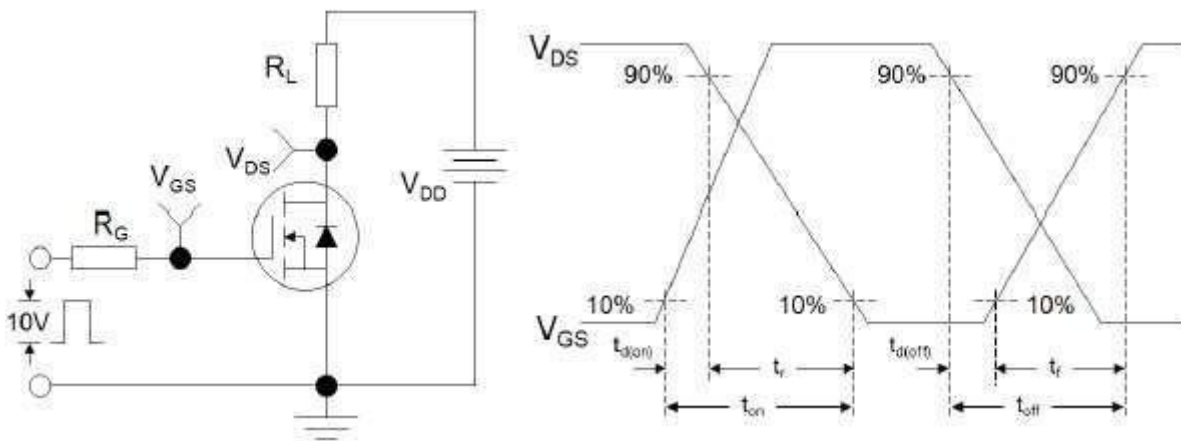


Figure 2: Resistive Switching Test Circuit & Waveforms

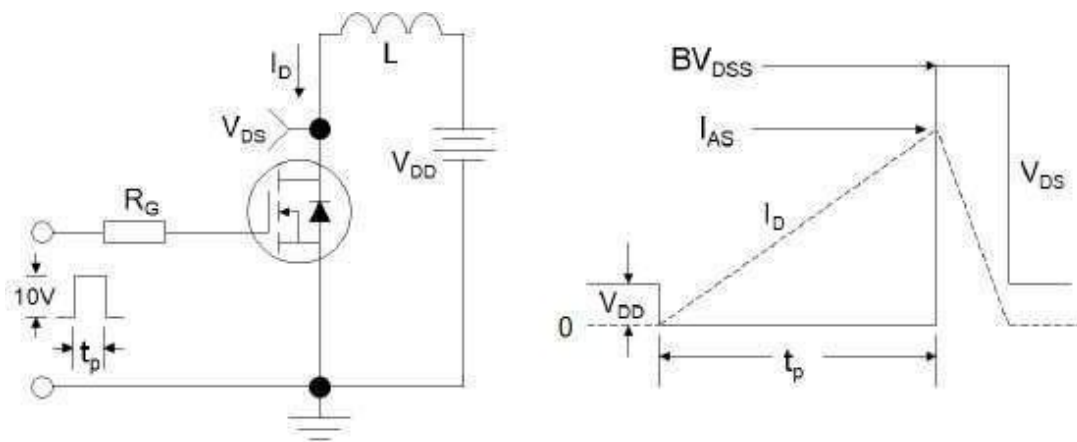
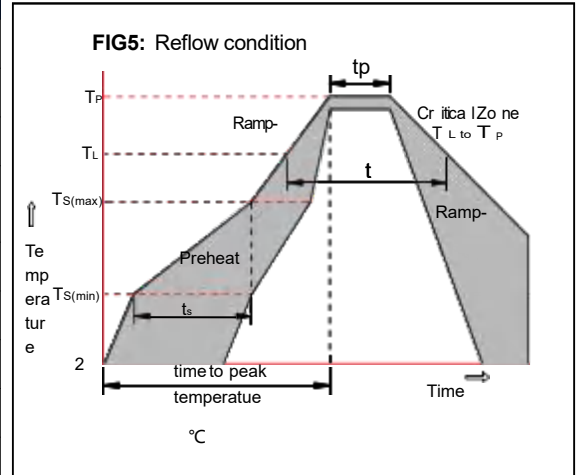


Figure 3:Unclamped Inductive Switching Test Circuit & Waveforms

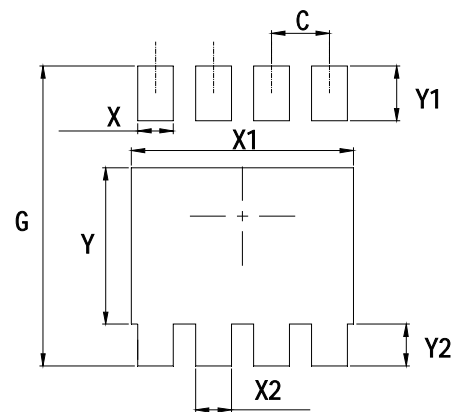
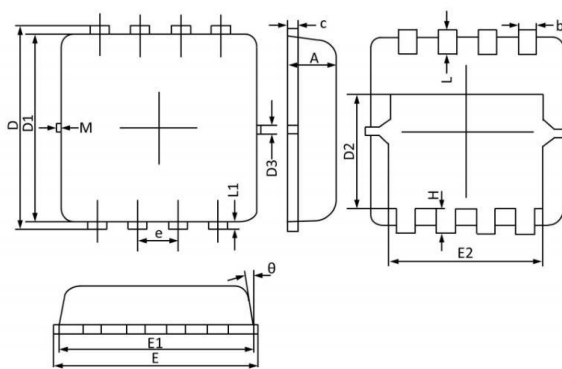
Soldering parameters

Reflow Condition		Pb-Free assembly (see as below)
Pre Heat	-Temperature Min ( $T_{s(min)}$ )	+150°C
	-Temperature Max( $T_{s(max)}$ )	+200°C
	-Time (Min to Max) (ts)	60-180 secs.
Average ramp up rate (Liquid us Temp ( $T_L$ ) to peak)		3°C/sec. Max
$T_{s(max)}$ to $T_L$ - Ramp-up Rate		3°C/sec. Max
Reflow	-Temperature( $T_L$ )(Liquid us)	+217°C
	-Temperature( $t_L$ )	60-150 secs.
Peak Temp ( $T_P$ )		+260(+0/-5)°C
Time within 5°C of actual Peak Temp ( $t_p$ )		30 secs. Max
Ramp-down Rate		6°C/sec. Max
Time 25°C to Peak Temp ( $T_P$ )		8 min. Max
Do not exceed		+260°C



Package Dimensions & Suggested Pad Layout

PDFN3X3 Package Information



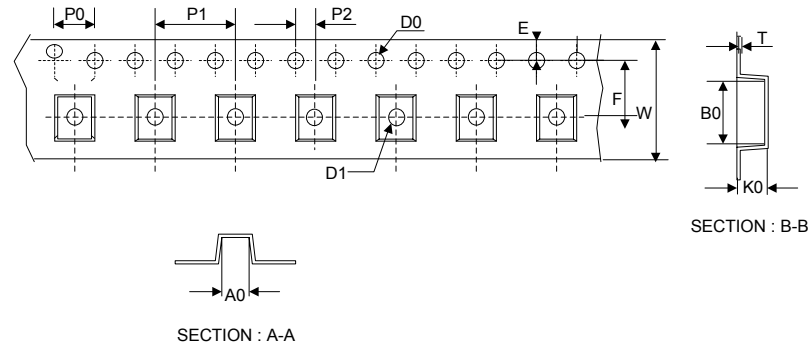
DIMENSIONS (unit : mm)

Symbol	Min	Typ	Max	Symbol	Min	Typ	Max
A	0.70	0.75	0.80	b	0.25	0.30	0.35
C	0.10	0.15	0.25	D	3.25	3.35	3.45
D1	3.00	3.10	3.20	D2	1.78	1.88	1.98
D3	--	0.13	--	E	3.20	3.30	3.40
E1	3.00	3.15	3.20	E2	2.39	2.49	2.59
e	0.65BSC			H	0.30	0.39	0.50
L	0.30	0.40	0.50	L1	--	0.13	--
theta	--	10°	12°	M	*	*	0.15

Dimensions	Value (in mm)
C	0.65
G	3.60
X	0.40
X1	2.60
X2	0.40
Y	1.95
Y1	0.62
Y2	0.55

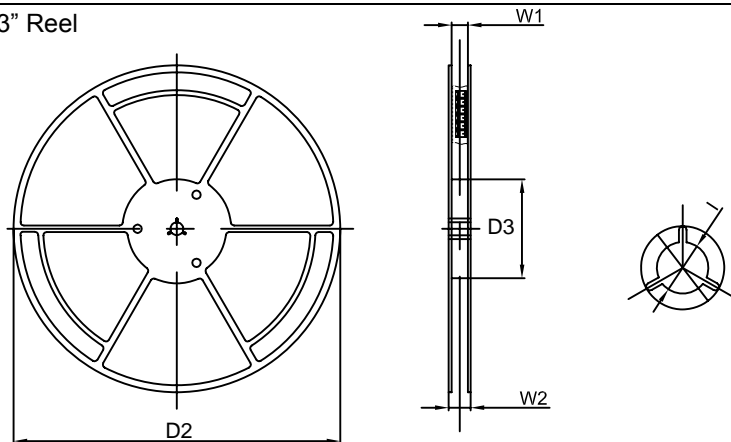
Tape & reel specification

Tape



Symbol	Dimension (mm)
P0	4.00±0.20
P1	8.00±0.20
P2	2.00±0.20
D0	1.55±0.20
D1	1.55±0.20
E	1.75±0.20
F	5.50±0.20
W	12.00±0.20
A0	3.90±0.20
B0	3.80±0.20
K0	1.20±0.20
T	0.20±0.20
D2	330.0±5.0
D3	100.0±4.0
W1	12.0±5.0
W2	14.0±5.0
I	13.0±2.0

13" Reel



Quantity: 5000PCS