

DESCRIPTION

This monolithic integrated circuit is an adjustable 3-terminal positive voltage regulator designed to supply more than 1.5A of load current with an output voltage adjustable over a 1.2 to 37V. It employs internal current limiting, thermal shut-down and safe area compensation.

FEATURES

- Internal thermal overload protection
- Internal short circuit current limiting
- Output transistor safe operating area compensation

TO-220

- 1.IN
- 2.GND
- 3.OUT

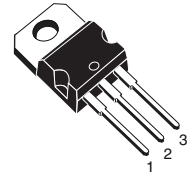

GK xxx
LM317T

MAXIMUM RATINGS AND ELECTRICAL CHARACTERISTICS

Absolute Maximum Ratings

Symbol	Parameter	Value	Unit
V_I-V_O	Input-Output Voltage Differential	40	V
T_{LEAD}	Lead Temperature	230	°C
P_D	Power Dissipation	Internally limited	W
T_J	Operating Junction Temperature Range	0~125	°C
T_{stg}	Storage Temperature Range	-55~125	
$\Delta V_O / \Delta T$	Temperature Coefficient of Output Voltage	±0.02	%/°C

Internal Block Diagram

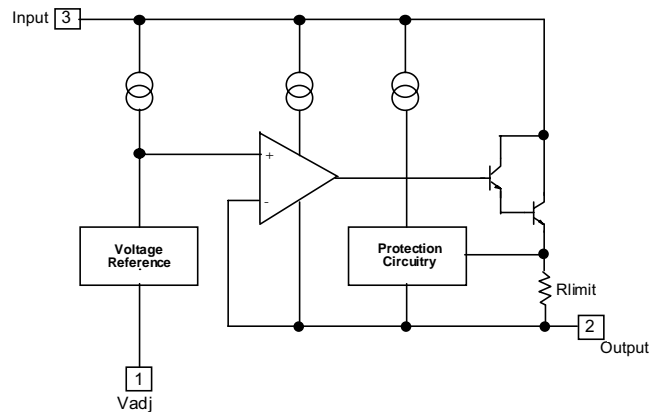

ELECTRICAL CHARACTERISTICS

($V_O - V_I = 5V, I_O = 0.5A, 0^\circ C \leq T_J \leq +125^\circ C, I_{MAX} = 1.5A, P_{DMAX} = 20W$, unless otherwise specified)

Parameter	Symbol	Test conditions	MIN	TYP	MAX	UNIT
Line Regulation(note1)	R_{line}	$T_A = 25^\circ C$ $3V \leq V_I - V_O \leq 40V$		0.01	0.04	% / V
		$3V \leq V_I - V_O \leq 40V$		0.02	0.07	
Load Regulation(note1)	R_{load}	$T_A = 25^\circ C, 10mA \leq I_O \leq I_{MAX}$ $V_O < 5V$ $V_O \geq 5V$		18 0.4	25 0.5	mV% / V_O
		$10mA \leq I_O \leq I_{MAX}$ $V_O < 5V$ $V_O \geq 5V$		40 0.8	70 1.5	
Adjustable Pin Current	I_{ADJ}	-		46	100	μA
Adjustable Pin Current Change	ΔI_{ADJ}	$3V \leq V_I - V_O \leq 40V$ $10mA \leq I_O \leq I_{MAX}, P_D \leq P_{MAX}$		2.0	5	
Reference Voltage	V_{REF}	$3V \leq V_I - V_O \leq 40V$ $10mA \leq I_O \leq I_{MAX}, P_D \leq P_{MAX}$	1.20	1.25	1.30	V
Temperature Stability	ST_T	-		0.7		% / V_O
Minimum Load Current to Maintain Regulation	$I_{L(MIN)}$	$V_I - V_O = 40V$		3.5	12	mA
Maximum Output Current	$I_{O(MAX)}$	$V_I - V_O \leq 15V, P_D \leq P_{MAX}$ $V_I - V_O \leq 40V, P_D \leq P_{MAX}$ $T_A = 25^\circ C$	1.0	2.2 0.3		A
RMS Noise, % of V_{OUT}	e_N	$T_A = 25^\circ C, 10Hz \leq f \leq 10KHz$		0.003	0.01	% / V_O
Ripple Rejection	RR	$V_O = 10V, f = 120Hz$ without C_{ADJ} $C_{ADJ} = 10\mu F$ (note2)	66	60 75		dB
Long-Term Stability, $T_J = T_{HIGH}$	ST	$T_A = 25^\circ C$ for end point mesasurements, 1000HR		0.3	1	%
Thermal Resistance Junction to case	$R_{\theta JC}$	-		5		$^\circ C/W$

Notes:

- Load and line regulation are specified at constant junction temperature. Change in V_D due to heating effects must be taken into account separately. Pulse testing with low duty is used. ($P_{MAX} = 20W$)
- C_{ADJ} . when used, is connected between the adjustment pin and ground.

Typical Application

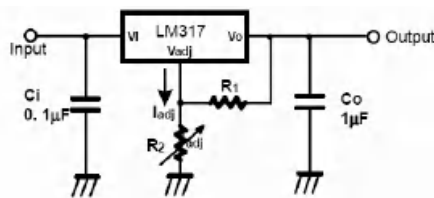

$$V_O = 1.25V (1 + R_2 / R_1) + I_{adj} R_2$$

C_i is required when regulator is located an appreciable distance from power supply filter.

C_o is not needed for stability , however, it does improve transient response.

Since I_{ADJ} is controlled to less than $100\mu A$, the error associated with this term is negligible in most applications.

Soldering parameters

Reflow Condition		Pb-Free assembly (see as below)
Pre Heat	-Temperature Min ($T_{s(min)}$)	+150 °C
	-Temperature Max($T_{s(max)}$)	+200 °C
	-Time (Min to Max) (ts)	60-180 secs.
Average ramp up rate (Liquid us Temp (T_L) to peak)		3 °C/sec. Max
$T_{s(max)}$ to T_L - Ramp-up Rate		3 °C/sec. Max
Reflow	-Temperature(T_L)(Liquid us)	+217 °C
	-Temperature(t_L)	60-150 secs.
Peak Temp (T_P)		+260(+0/-5) °C
Time within 5 °C of actual Peak Temp (t_p)		30 secs. Max
Ramp-down Rate		6 °C/sec. Max
Time 25 °C to Peak Temp (T_P)		8 min. Max
Do not exceed		+260 °C



Package Dimensions & Suggested Pad Layout

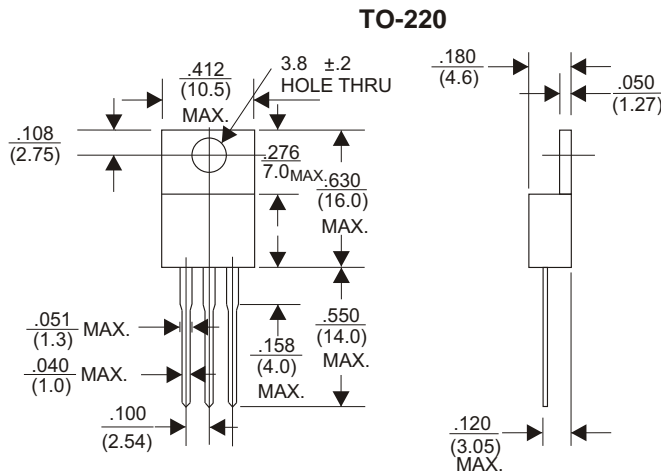

Dimensions in inches and (millimeters)