

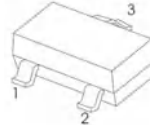

## FEATURES

- Complementary to S9015

### SOT-23



M6

- 1.BASE  
2.EMITTER  
3.COLLECTOR

## MAXIMUM RATINGS AND ELECTRICAL CHARACTERISTICS

### MAXIMUM RATINGS

Rating	Symbol	Value	Unit
Collector–Emitter Voltage	$V_{CEO}$	-45	Vdc
Collector–Base Voltage	$V_{CBO}$	-50	Vdc
Emitter–Base Voltage	$V_{EBO}$	-5.0	Vdc
Collector Current — Continuous	$I_c$	-100	mAdc

### THERMAL CHARACTERISTICS

Characteristic	Symbol	Max	Unit
Total Device Dissipation FR– 5 Board, (1) $T_A = 25^\circ\text{C}$	$P_D$	200	mW
Junction and Storage Temperature	$T_J, T_{stg}$	- 55 to +150	$^\circ\text{C}$

### CLASSIFICATION OF $h_{FE}$

Rank	L	H
Range	200-450	400-1000

**ELECTRICAL CHARACTERISTICS (TA = 25°C unless otherwise noted.)**

**OFF CHARACTERISTICS**

Characteristic	Symbol	Min	Max	Unit
Collector–Emitter Breakdown Voltage(3) ( $I_C = -0.1 \text{ mA}$ , $I_B = 0$ )	$V_{(BR)CEO}$	-45	–	Vdc
Collector–Base Breakdown Voltage ( $I_C = -100 \mu\text{A}$ , $I_E = 0$ )	$V_{(BR)CBO}$	-50	–	Vdc
Emitter–Base Breakdown Voltage ( $I_E = -100 \mu\text{A}$ , $I_C = 0$ )	$V_{(BR)EBO}$	-5.0	–	Vdc
Collector cut-off current ( $V_{CB} = -50 \text{ Vdc}$ , $I_E = 0$ )	$I_{CBO}$	–	-0.1	$\mu\text{A}$
Emitter cut-off current ( $V_{EB} = -5 \text{ Vdc}$ , $I_C = 0$ )	$I_{EBO}$	–	-0.1	$\mu\text{A}$

- FR-5 = 1.0 x 0.75 x 0.062 in.
- Alumina = 0.4 x 0.3 x 0.024 in. 99.5% alumina.
- Pulse Test: Pulse Width <300  $\mu\text{s}$ , Duty Cycle <2.0%.

**ON CHARACTERISTICS**

Characteristic	Symbol	Min	Max	Unit
DC Current Gain	$h_{FE}$			—
( $I_C = -1.0 \text{ mA}$ , $V_{CE} = -5 \text{ Vdc}$ )		200	1000	
Collector–Emitter Saturation Voltage	$V_{CE(sat)}$			Vdc
( $I_C = -100 \text{ mA}$ , $I_B = -10 \text{ mA}$ )(3)		—	-0.3	
Base–Emitter Saturation Voltage(3)	$V_{BE(sat)}$			Vdc
( $I_C = -100 \text{ mA}$ , $I_B = -10 \text{ mA}$ )		—	-1.0	

**SMALL–SIGNAL CHARACTERISTICS**

Current–Gain — Bandwidth Product ( $I_C = -10 \text{ mA}$ , $V_{CE} = -5.0 \text{ Vdc}$ , $f = 30 \text{ MHz}$ )	$f_T$	150	–	MHz
---	-------	-----	---	-----

**RATING AND CHARACTERISTIC CURVES**

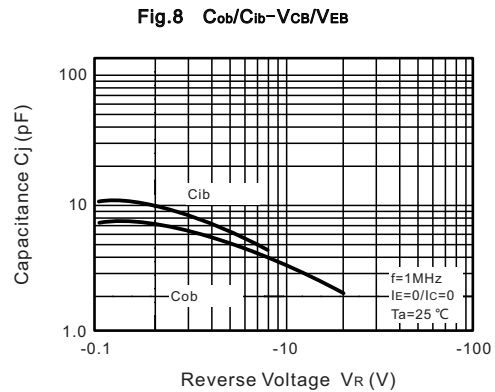
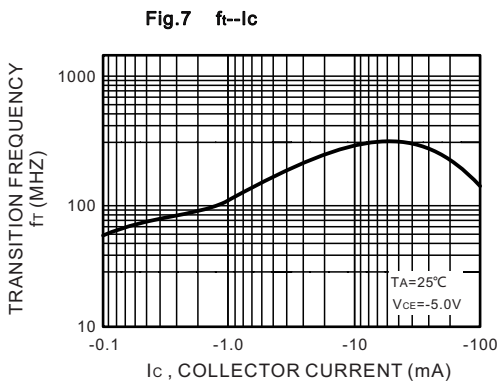
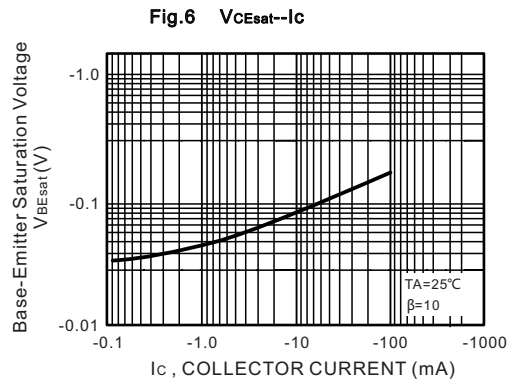
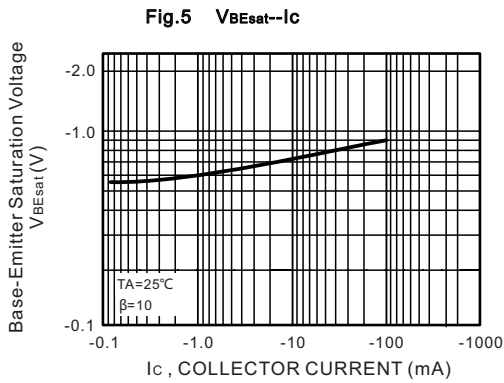
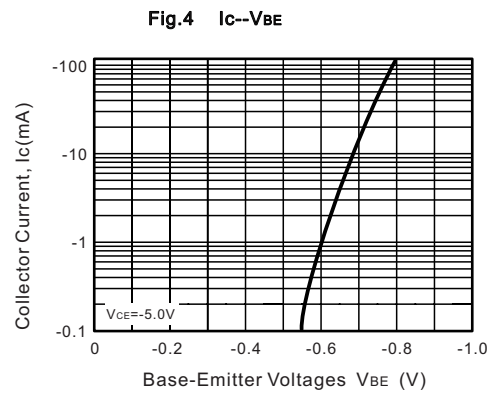
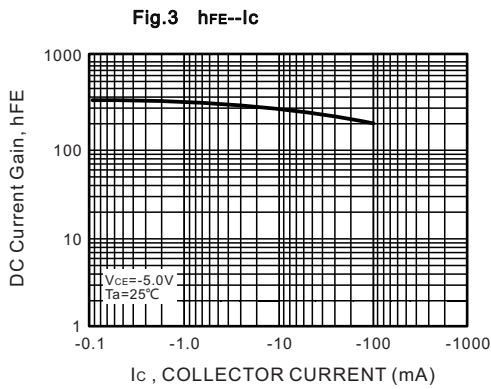
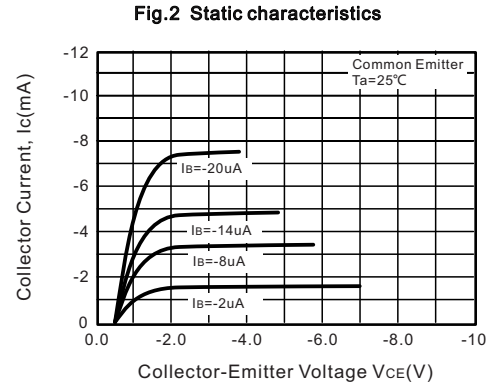
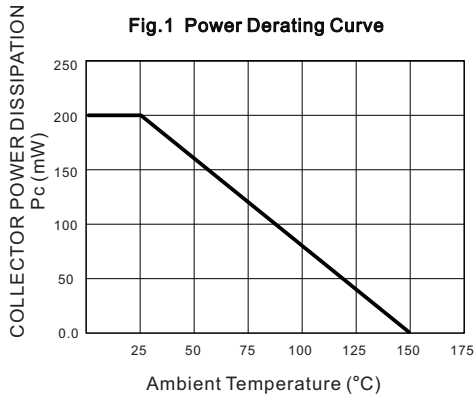

**Soldering parameters**

Reflow Condition		Pb-Free assembly (see as below)
Pre Heat	-Temperature Min ( $T_{s(min)}$ )	+150°C
	-Temperature Max( $T_{s(max)}$ )	+200°C
	-Time (Min to Max) (ts)	60-180 secs.
Average ramp up rate (Liquid us Temp ( $T_L$ ) to peak)		3°C/sec. Max
$T_{s(max)}$ to $T_L$ - Ramp-up Rate		3°C/sec. Max
Reflow	-Temperature( $T_L$ )(Liquid us)	+217°C
	-Temperature( $t_L$ )	60-150 secs.
Peak Temp ( $T_P$ )		+260(+0/-5)°C
Time within 5°C of actual Peak Temp ( $t_p$ )		30 secs. Max
Ramp-down Rate		6°C/sec. Max
Time 25°C to Peak Temp ( $T_P$ )		8 min. Max
Do not exceed		+260°C



**Package Dimensions & Suggested Pad Layout**

**SOT23**

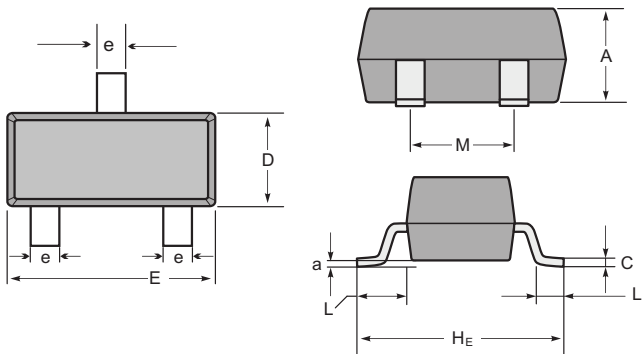

**SOT-23 mechanical data**

UNIT	A	C	D	E	$H_e$	e	M	L	$L_1$	a	
mm	max	1.1	0.15	1.4	3.0	2.6	0.5	1.95	0.55 (ref)	0.36 (ref)	0.0
	min	0.9	0.08	1.2	2.8	2.2	0.3	1.7			0.15
mil	max	43	6	55	118	102	20	77	22 (ref)	14 (ref)	0.0
	min	35	3	47	110	87	12	67			6

Dimensions	SOT23
<b>Z</b>	2.9
<b>X</b>	0.8
<b>Y</b>	0.9
<b>C</b>	2.0
<b>E</b>	1.35

Tape & reel specification

Tape

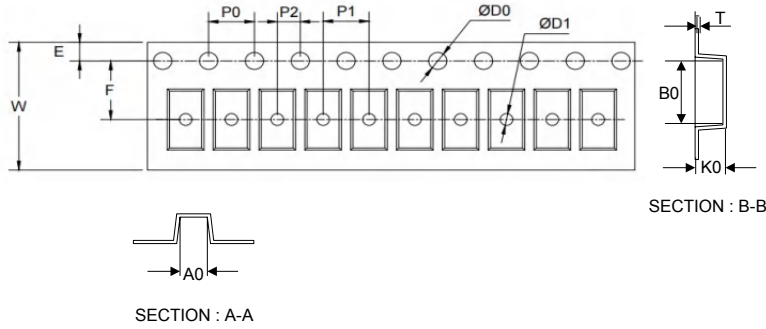

Symbol	Dimension (mm)
P0	4.00±0.10
P1	4.00±0.10
P2	2.00±0.10
D0	1.55±0.10
D1	1.05±0.10
E	1.55±0.10
F	3.60±0.10
W	8.00±0.10
A0	3.80±0.20
B0	3.25±0.20
K0	1.45±0.10
T	0.25±0.05
D2	178.0±3.0
D3	55Min.
D4	R24.0±3.0
G	R82.0±3.0
I	13.0±2.0
W1	11.0±3.0

7" Reel



Quantity: 3000PCS