

FEATURES

High density cell design for low $R_{DS(ON)}$
Voltage controlled small signal switch
Rugged and reliable
High saturation current capability

V_{DSS} 30 V
 I_D 5.8 A
 $R_{DS(ON)}$ 21 m Ω

A09T

SOT-23

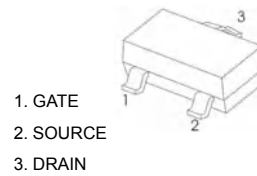

Equivalent Circuit

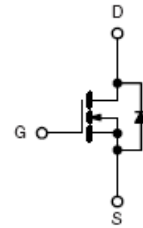

MAXIMUM RATINGS AND ELECTRICAL CHARACTERISTICS

Maximum ratings ($T_a=25^\circ\text{C}$ unless otherwise noted)

Parameter	Symbol	Value	Unit
Drain-Source Voltage	V_{DS}	30	V
Gate-Source Voltage	V_{GS}	± 12	V
Continuous Drain Current	I_D	5.8	A
Drain Current-Pulsed (note 1)	I_{DM}	30	A
Power Dissipation	P_D	1.5	W
Thermal Resistance from Junction to Ambient (note 2)	$R_{\theta JA}$	357	$^\circ\text{C/W}$
Junction Temperature	T_J	150	$^\circ\text{C}$
Storage Temperature	T_{STG}	-55~+150	$^\circ\text{C}$

Electrical Characteristics (T_J=25°C unless otherwise specified)

Parameter	Symbol	Test Condition	Min	Typ	Max	Units
Off Characteristics						
Drain-source breakdown voltage	V _{(BR)DSS}	V _{GS} = 0V, I _D = 250μA	30			V
Zero gate voltage drain current	I _{DSS}	V _{DS} = 24V, V _{GS} = 0V			1	μA
Gate-source leakage current	I _{GSS}	V _{GS} = ±12V, V _{DS} = 0V			±100	nA
On characteristics						
Drain-source on-resistance (note 3)	R _{DS(on)}	V _{GS} = 10V, I _D = 5.8A		21	28	mΩ
		V _{GS} = 4.5V, I _D = 5A			38	mΩ
		V _{GS} = 2.5V, I _D = 4A			52	mΩ
Forward tranconductance	g _{FS}	V _{DS} = 5V, I _D = 5A	8			S
Gate threshold voltage	V _{GS(th)}	V _{DS} = V _{GS} , I _D = 250μA	0.7		1.4	V
Dynamic Characteristics (note 4,5)						
Input capacitance	C _{iss}	V _{DS} = 15V, V _{GS} = 0V, f = 1MHz			1050	pF
Output capacitance	C _{oss}			99		pF
Reverse transfer capacitance	C _{rss}			77		pF
Gate resistance	R _g	V _{DS} = 0V, V _{GS} = 0V, f = 1MHz			3.6	Ω
Switching Characteristics (note 4,5)						
Turn-on delay time	t _{d(on)}	V _{GS} = 10V, V _{DS} = 15V, R _L = 2.7Ω, R _{GEN} = 3Ω			5	ns
Turn-on rise time	t _r				7	ns
Turn-off delay time	t _{d(off)}				40	ns
Turn-off fall time	t _f				6	ns
Drain-source diode characteristics and maximum ratings						
Diode forward voltage (note 3)	V _{SD}	I _S = 1A, V _{GS} = 0V			1	V

Note :

1. Repetitive Rating : Pulse width limited by maximum junction temperature.
2. Surface Mounted on FR4 Board, t < 5 sec.
3. Pulse Test : Pulse Width ≤ 300μs, Duty Cycle ≤ 2%.
4. Guaranteed by design, not subject to production testing.

RATING AND CHARACTERISTIC CURVES

Output Characteristics

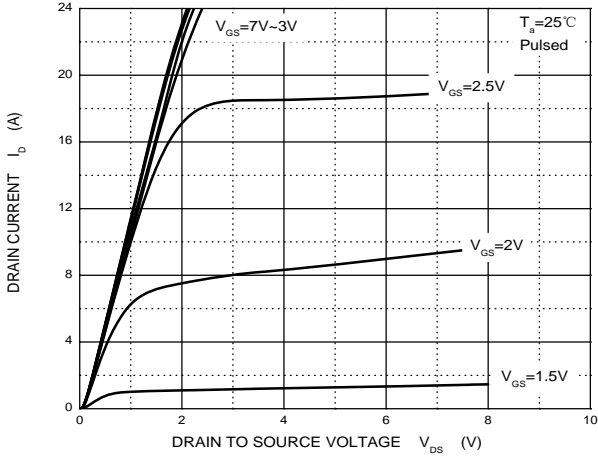

Transfer Characteristics

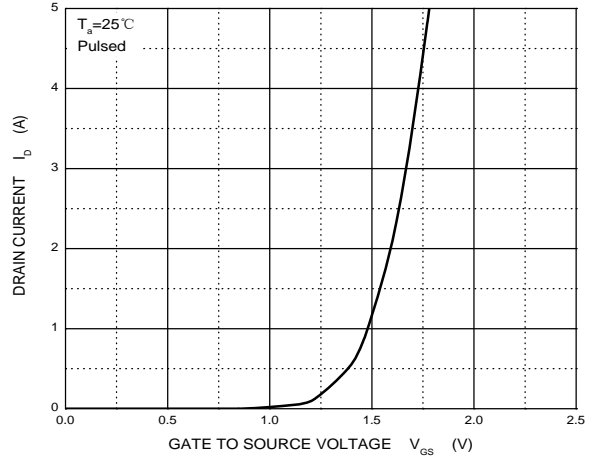

$R_{DS(ON)}$ — I_D

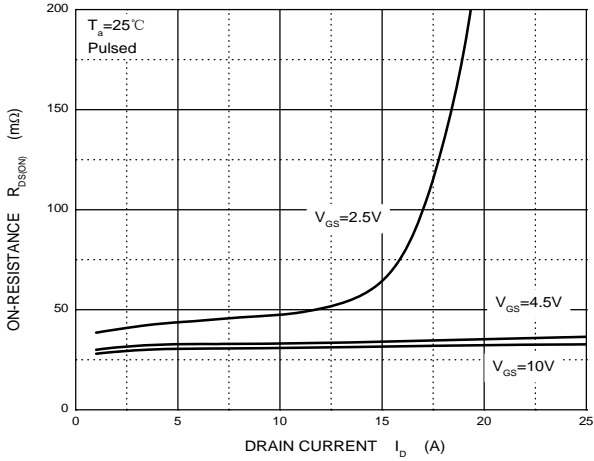

$R_{DS(ON)}$ — V_{GS}

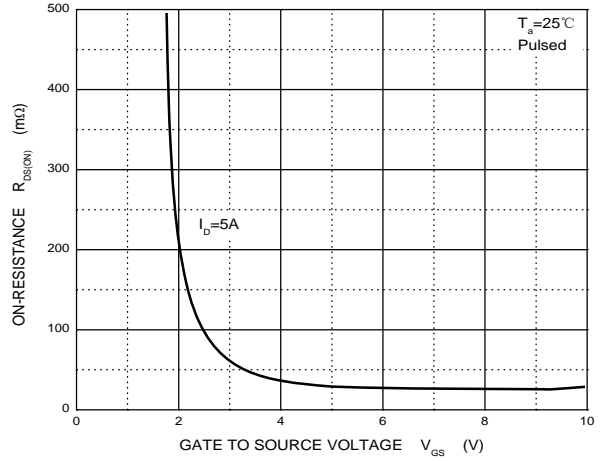

I_S — V_{SD}

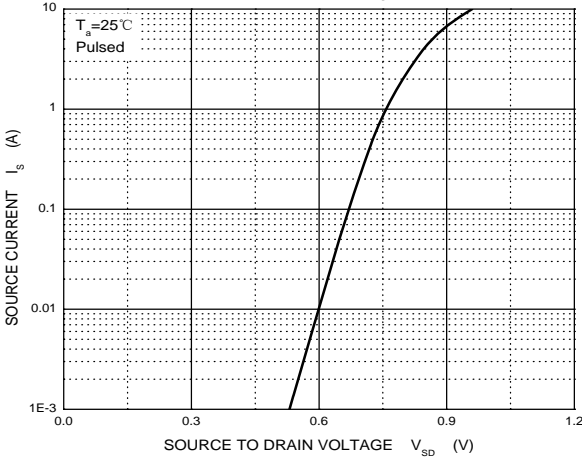

Soldering parameters

Reflow Condition		Pb-Free assembly (see as below)
Pre Heat	-Temperature Min ($T_{s(min)}$)	+150 °C
	-Temperature Max($T_{s(max)}$)	+200 °C
	-Time (Min to Max) (ts)	60-180 secs.
Average ramp up rate (Liquid us Temp (T_L) to peak)		3 °C/sec. Max
$T_{s(max)}$ to T_L - Ramp-up Rate		3 °C/sec. Max
Reflow	-Temperature(T_L)(Liquid us)	+217 °C
	-Temperature(t_L)	60-150 secs.
Peak Temp (T_P)		+260(+0/-5) °C
Time within 5 °C of actual Peak Temp (t_p)		30 secs. Max
Ramp-down Rate		6 °C/sec. Max
Time 25 °C to Peak Temp (T_P)		8 min. Max
Do not exceed		+260 °C



Package Dimensions & Suggested Pad Layout

SOT23

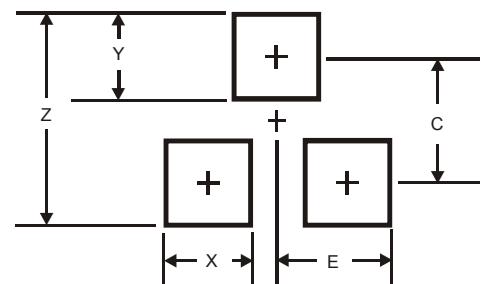
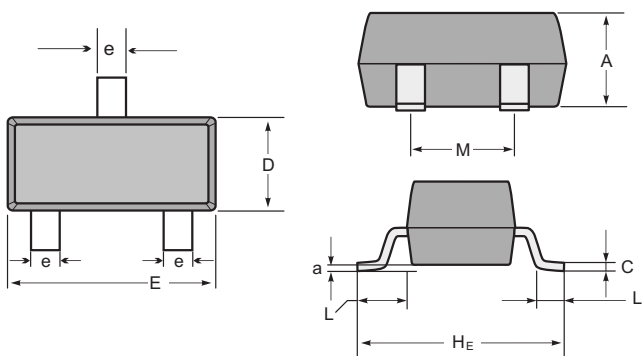

SOT-23 mechanical data

UNIT	A	C	D	E	HE	e	M	L	L1	a	
mm	max	1.1	0.15	1.4	3.0	2.6	0.5	1.95	0.55 (ref)	0.36 (ref)	0.0
	min	0.9	0.08	1.2	2.8	2.2	0.3	1.7			0.15
mil	max	43	6	55	118	102	20	77	22 (ref)	14 (ref)	0.0
	min	35	3	47	110	87	12	67			6

Dimensions	SOT23
Z	2.9
X	0.8
Y	0.9
C	2.0
E	1.35

Tape & reel specification

Tape

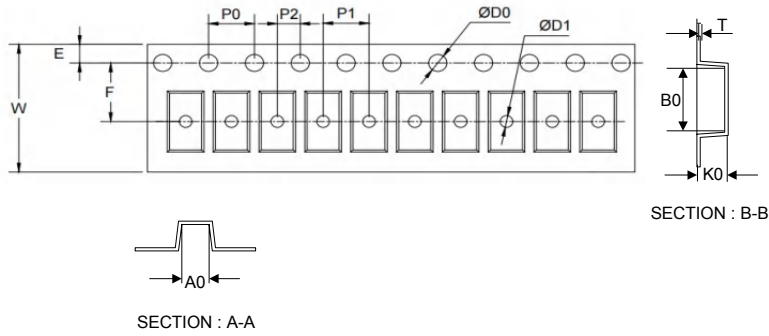

Symbol	Dimension (mm)
P0	4.00±0.10
P1	4.00±0.10
P2	2.00±0.10
D0	1.55±0.10
D1	1.05±0.10
E	1.55±0.10
F	3.60±0.10
W	8.00±0.10
A0	3.80±0.20
B0	3.25±0.20
K0	1.45±0.10
T	0.25±0.05
D2	178.0±3.0
D3	55Min.
D4	R24.0±3.0
G	R82.0±3.0
I	13.0±2.0
W1	11.0±3.0

7" Reel

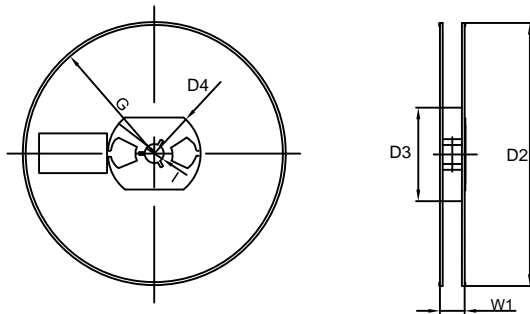

Quantity: 3000PCS