

## FEATURES

- Epitaxial Planar Die Construction
- Complementary NPN Types Available (MMBTA55 / MMBTA56)
- Ideal for Low Power Amplification and Switching

### SOT-23

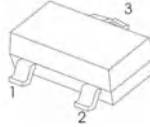

1.BASE  
2.EMITTER  
3.COLLECTOR

MMBTA55 Marking: 2H  
MMBTA56 Marking: 2GM

2H

2GM

## MAXIMUM RATINGS AND ELECTRICAL CHARACTERISTICS

### Maximum Ratings @ $T_A = 25^\circ\text{C}$ unless otherwise specified

| Characteristic                          | Symbol          | MMBTA55     | MMBTA56 | Unit               |
|---|-----------------|-------------|---------|--------------------|
| Collector-Base Voltage                  | $V_{CB0}$       | -60         | -80     | V                  |
| Collector-Emitter Voltage               | $V_{CEO}$       | -60         | -80     | V                  |
| Emitter-Base Voltage                    | $V_{EBO}$       | -4.0        |         | V                  |
| Collector Current - Continuous          | $I_C$           | -500        |         | mA                 |
| Power Dissipation                       | $P_d$           | 300         |         | mW                 |
| Thermal Resistance, Junction to Ambient | $R_{\theta JA}$ | 417         |         | $^\circ\text{C/W}$ |
| Operating and Storage Temperature Range | $T_j, T_{STG}$  | -55 to +150 |         | $^\circ\text{C}$   |

Electrical Characteristics  $T_a = 25^\circ\text{C}$

| Characteristic                       |                    | Symbol        | Min        | Max   | Unit | Test Condition  |
|--------------------------------------|--------------------|---------------|------------|-------|------|---|
| <b>OFF CHARACTERISTICS</b>           |                    |               |            |       |      |   |
| Collector-Base Breakdown Voltage     | MMBTA55<br>MMBTA56 | $V_{(BR)CBO}$ | -60<br>-80 | —     | V    | $I_C = -100\mu\text{A}, I_E = 0$  |
| Collector-Emitter Breakdown Voltage  | MMBTA55<br>MMBTA56 | $V_{(BR)CEO}$ | -60<br>-80 | —     | V    | $I_C = -1.0\text{mA}, I_B = 0$  |
| Emitter-Base Breakdown Voltage       |                    | $V_{(BR)EBO}$ | -4.0       | —     | V    | $I_E = -100\mu\text{A}, I_C = 0$  |
| Collector Cutoff Current             | MMBTA55<br>MMBTA56 | $I_{CBO}$     | —          | -100  | nA   | $V_{CB} = -60\text{V}, I_E = 0$<br>$V_{CB} = -80\text{V}, I_E = 0$                          |
| Collector Cutoff Current             | MMBTA55<br>MMBTA56 | $I_{CEX}$     | —          | -100  | nA   | $V_{CE} = -60\text{V}, I_{BO} = 0\text{V}$<br>$V_{CE} = -80\text{V}, I_{BO} = 0\text{V}$    |
| <b>ON CHARACTERISTICS</b>            |                    |               |            |       |      |   |
| DC Current Gain                      |                    | $h_{FE}$      | 100        | —     | —    | $I_C = -10\text{mA}, V_{CE} = -1.0\text{V}$<br>$I_C = -100\text{mA}, V_{CE} = -1.0\text{V}$ |
| Collector-Emitter Saturation Voltage |                    | $V_{CE(SAT)}$ | —          | -0.25 | V    | $I_C = -100\text{mA}, I_B = -10\text{mA}$   |
| Base-Emitter Saturation Voltage      |                    | $V_{BE(SAT)}$ | —          | -1.2  | V    | $I_C = -100\text{mA}, V_{CE} = -1.0\text{V}$  |
| <b>SMALL SIGNAL CHARACTERISTICS</b>  |                    |               |            |       |      |   |
| Current Gain-Bandwidth Product       |                    | $f_T$         | 50         | —     | MHz  | $V_{CE} = -1.0\text{V}, I_C = -100\text{mA},$<br>$f = 100\text{MHz}$                        |

**RATING AND CHARACTERISTIC CURVES**

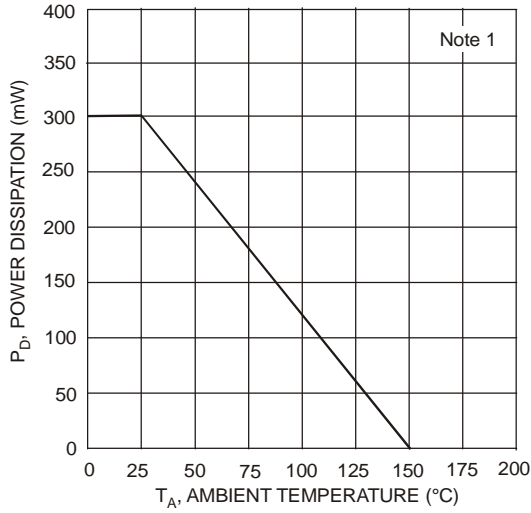

Fig. 1 Max Power Dissipation vs Ambient Temperature

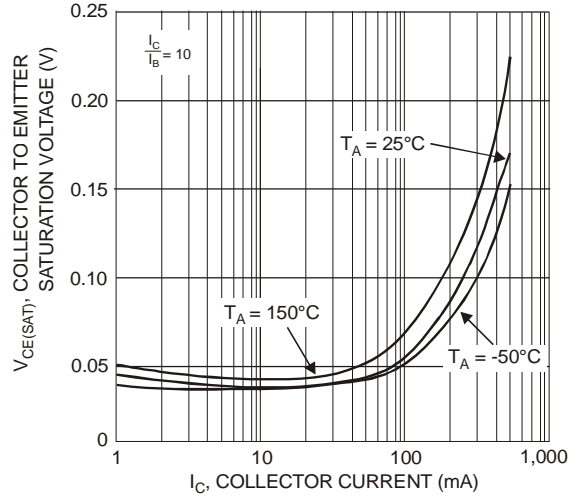

Fig. 2 Collector Emitter Saturation Voltage vs. Collector Current

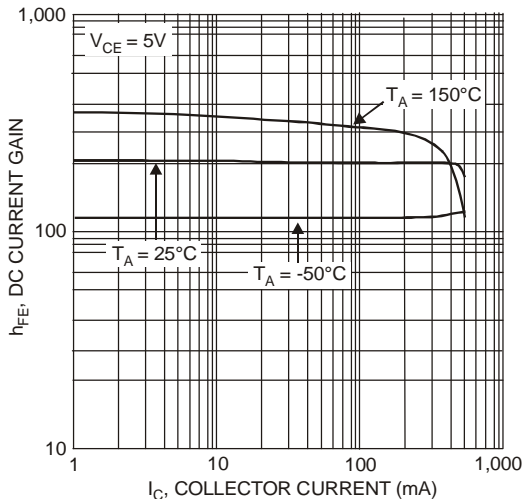

Fig. 3 DC Current Gain vs. Collector Current

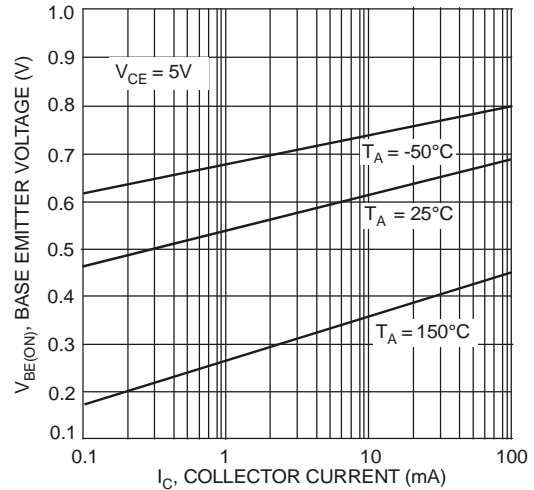
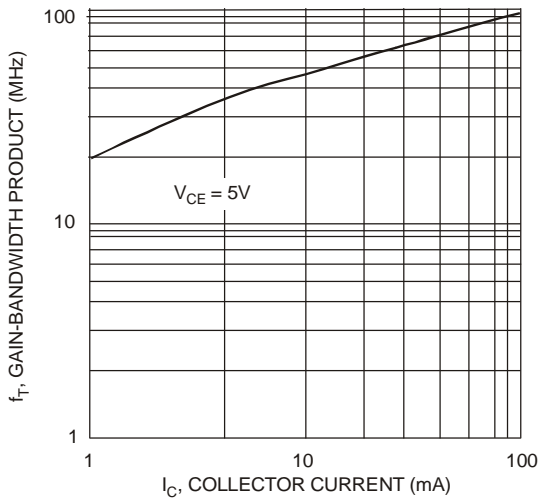

Fig. 4 Base Emitter Voltage vs. Collector Current



**Soldering parameters**

| Reflow Condition  |                                   | Pb-Free assembly<br>(see as below) |
|---|-----------------------------------|------------------------------------|
| Pre Heat  | -Temperature Min ( $T_{s(min)}$ ) | +150°C                             |
|   | -Temperature Max( $T_{s(max)}$ )  | +200°C                             |
|   | -Time (Min to Max) (ts)           | 60-180 secs.                       |
| Average ramp up rate (Liquid us Temp ( $T_L$ ) to peak) |                                   | 3°C/sec. Max                       |
| $T_{s(max)}$ to $T_L$ - Ramp-up Rate                    |                                   | 3°C/sec. Max                       |
| Reflow  | -Temperature( $T_L$ )(Liquid us)  | +217°C                             |
|   | -Temperature( $t_L$ )             | 60-150 secs.                       |
| Peak Temp ( $T_P$ )                                     |                                   | +260(+0/-5)°C                      |
| Time within 5°C of actual Peak Temp ( $t_p$ )           |                                   | 30 secs. Max                       |
| Ramp-down Rate  |                                   | 6°C/sec. Max                       |
| Time 25°C to Peak Temp ( $T_P$ )                        |                                   | 8 min. Max                         |
| Do not exceed   |                                   | +260°C                             |



**Package Dimensions & Suggested Pad Layout**

**SOT23**

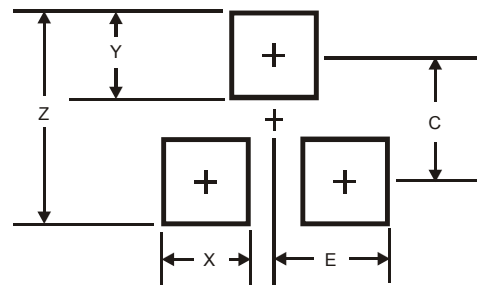
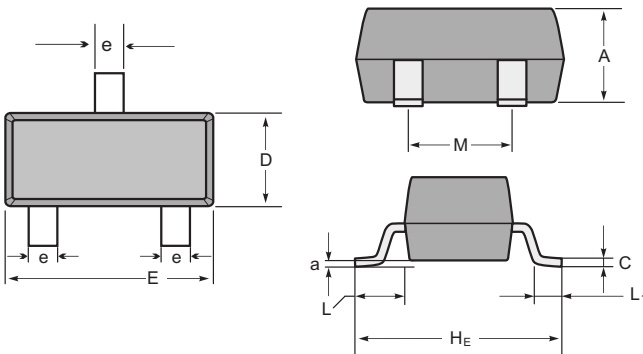

**SOT-23 mechanical data**

| UNIT | A   | C   | D    | E   | $H_e$ | e   | M   | L    | $L_1$      | a          |      |
|------|-----|-----|------|-----|-------|-----|-----|------|------------|------------|------|
| mm   | max | 1.1 | 0.15 | 1.4 | 3.0   | 2.6 | 0.5 | 1.95 | 0.55 (ref) | 0.36 (ref) | 0.0  |
|      | min | 0.9 | 0.08 | 1.2 | 2.8   | 2.2 | 0.3 | 1.7  |            |            | 0.15 |
| mil  | max | 43  | 6    | 55  | 118   | 102 | 20  | 77   | 22 (ref)   | 14 (ref)   | 0.0  |
|      | min | 35  | 3    | 47  | 110   | 87  | 12  | 67   |            |            | 6    |

| Dimensions | SOT23 |
|------------|-------|
| Z          | 2.9   |
| X          | 0.8   |
| Y          | 0.9   |
| C          | 2.0   |
| E          | 1.35  |

Tape & reel specification

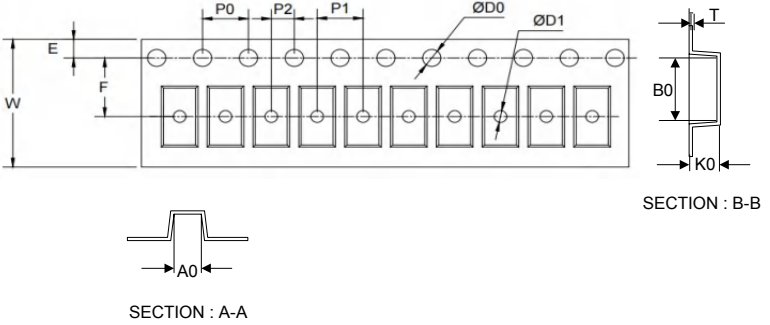
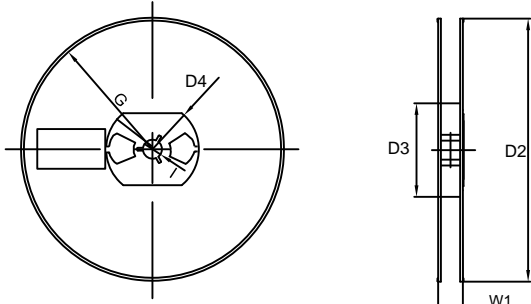
| Tape   | Symbol   | Dimension (mm) |           |
|--|--|----------------|-----------|
|  | P0   | 4.00±0.10      |           |
|  | P1   | 4.00±0.10      |           |
|  | P2   | 2.00±0.10      |           |
|  | D0   | 1.55±0.10      |           |
|  | D1   | 1.05±0.10      |           |
|  | E  | 1.55±0.10      |           |
|  | F  | 3.60±0.10      |           |
|  | W  | 8.00±0.10      |           |
|  | A0   | 3.80±0.20      |           |
|  | B0   | 3.25±0.20      |           |
|  | K0   | 1.45±0.10      |           |
|  | T  | 0.25±0.05      |           |
|  | <p>7" Reel</p>  | D2             | 178.0±3.0 |
|  |  | D3             | 55Min.    |
| D4   |  | R24.0±3.0      |           |
| G  |  | R82.0±3.0      |           |
| I  |  | 13.0±2.0       |           |
| W1   |  | 11.0±3.0       |           |
| Quantity: 3000PCS  |  |                |           |