

FEATURES

- * For surface mount application
- * Built-in strain relief
- * Excellent clamping capability
- * Low profile package
- * Fast response time: Typically less than 1.0ps from 0 volt to BV min.
- * Typical I_R less than 1 A above 10V
- * High temperature soldering guaranteed: 260°C / 10 seconds at terminals

MECHANICAL DATA

- * Case: Molded plastic
- * Epoxy: UL 94V-0 rate flame retardant
- * Lead: Solderable per MIL-STD-202, method 208 guaranteed
- * Polarity: Color band denotes cathode end except Bidirectional
- * Mounting position: Any
- * Weight: 0.063 grams



- "GK" represents the brand name
- "XXX" represents the periodic code
- "YY" represents the product type marking

VOLTAGE RANGE

5.0 to 440 Volts
400 Watts Peak Power

MAXIMUM RATINGS AND ELECTRICAL CHARACTERISTICS

Rating 25°C ambient temperature unless otherwise specified.
Single phase half wave, 60Hz, resistive or inductive load.
For capacitive load, derate current by 20%.

RATINGS	SYMBOL	VALUE	UNITS
Peak Power Dissipation at $T_A=25^\circ\text{C}$, $T_P=1\text{ms}$ (NOTE 1)	P_{PK}	Minimum 400	Watts
Peak Forward Surge Current at 8.3ms Single Half Sine-Wave superimposed on rated load (JEDEC method) (NOTE 3)	I_{FSM}	60	Amps
Operating and Storage Temperature Range	T_J, T_{STG}	-55 to +150	°C

NOTES:

1. Non-repetitive current pulse per Fig. 3 and derated above $T_A=25^\circ\text{C}$ per Fig. 2.
2. Mounted on Copper Pad area of 5.0mm^2 (.013mm Thick) to each terminal.
3. 8.3ms single half sine-wave, duty cycle = 4 pulses per minute maximum.

DEVICES FOR BIDIRECTIONAL APPLICATIONS

1. For bi-directional use C suffix for Types .
2. Electrical characteristics apply in both directions.

RATING AND CHARACTERISTIC CURVES

FIG.1-PEAK PULSE POWER DERATING CURVE

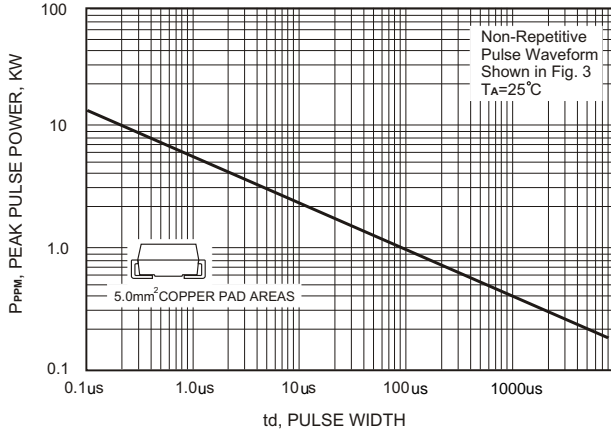

FIG.2-PULSE DERATING CURVE

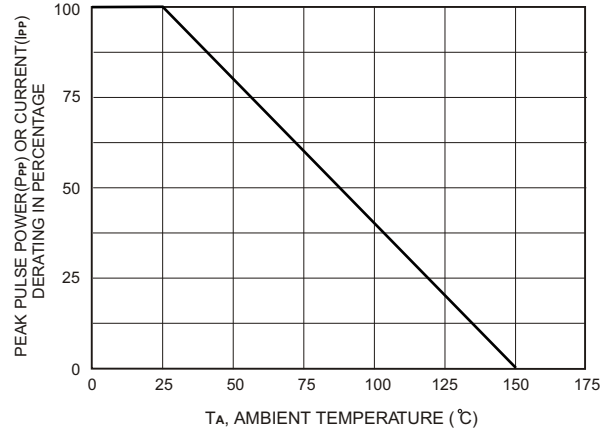

FIG.3-PULSE WAVE FORM

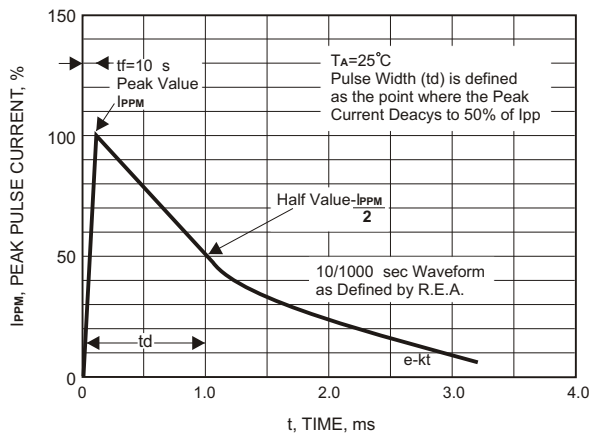

FIG.4 MAXIMUM NON REPETITIVE PEAK FORWARD SURGE CURRENT

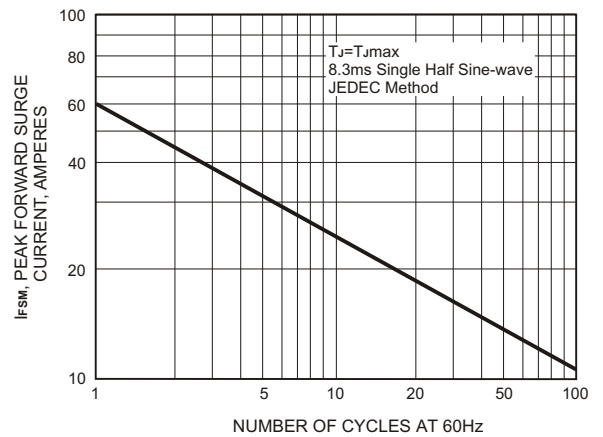
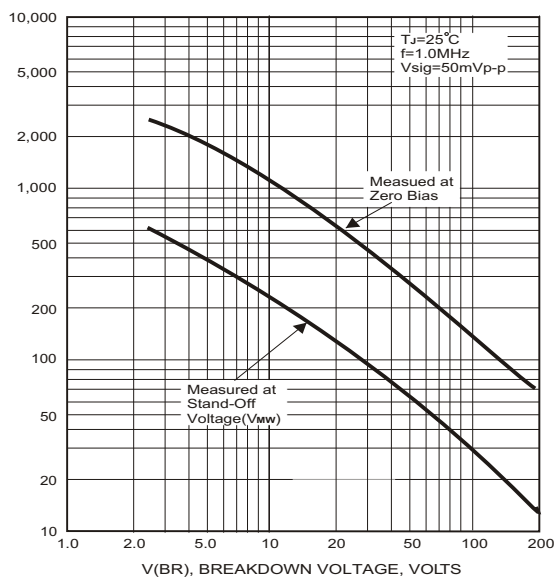

FIG.5-TYPICAL JUNCTION CAPACITANCE



PART NUMBER ADD C FOR BI- DIRECTIONAL	REVERSE STAND-OFF VOLTAGE VRWM (V)	BREAKDOWN VOLTAGE VBR (V)		TEST CURRENT IT (mA)	MAXIMUM CLAMPING VOLTAGE @Ipp Vc (V)	PEAK PULSE CURRENT Ipp (A)	REVERSE LEAKAGE @ VRWM IR(μA)	MARKING CODE	
		MIN. @IT	MAX. @IT					UNI	BI
See Note 1									
SMAJ5.0(C)A	5.0	6.40	7.25	10	9.2	43.5	800	AE	WE
SMAJ6.0(C)A	6.0	6.67	7.67	10	10.3	38.8	800	AG	WG
SMAJ6.5(C)A	6.5	7.22	8.30	10	11.2	35.7	500	AK	WK
SMAJ7.0(C)A	7.0	7.78	8.95	10	12.0	33.3	200	AM	WM
SMAJ7.5(C)A	7.5	8.33	9.58	1	12.9	31.0	100	AP	WP
SMAJ8.0(C)A	8.0	8.89	10.23	1	13.6	29.4	50	AR	WR
SMAJ8.5(C)A	8.5	9.44	10.82	1	14.4	27.7	10	AT	WT
SMAJ9.0(C)A	9.0	10.0	11.50	1	15.4	26.0	5	AV	WV
SMAJ10(C)A	10	11.1	12.80	1	17.0	23.5	5	AX	WX
SMAJ11(C)A	11	12.2	14.00	1	18.2	22.0	5	AZ	WZ
SMAJ12(C)A	12	13.3	15.30	1	19.9	20.1	5	BE	XE
SMAJ13(C)A	13	14.4	16.50	1	21.5	18.6	5	BG	XG
SMAJ14(C)A	14	15.6	17.90	1	23.2	17.2	5	BK	XK
SMAJ15(C)A	15	16.7	19.20	1	24.4	16.4	5	BM	XM
SMAJ16(C)A	16	17.8	20.50	1	26.0	15.3	5	BP	XP
SMAJ17(C)A	17	18.9	21.70	1	27.6	14.5	5	BR	XR
SMAJ18(C)A	18	20.0	23.30	1	29.2	13.7	5	BT	XT
SMAJ20(C)A	20	22.2	25.50	1	32.4	12.3	5	BV	XV
SMAJ22(C)A	22	24.4	28.00	1	35.5	11.2	5	BX	XX
SMAJ24(C)A	24	26.7	30.70	1	38.9	10.3	5	BZ	XZ
SMAJ26(C)A	26	28.9	33.20	1	42.1	9.5	5	CE	YE
SMAJ28(C)A	28	31.1	35.80	1	45.4	8.8	5	CG	YG
SMAJ30(C)A	30	33.3	38.30	1	48.4	8.3	5	CK	YK
SMAJ33(C)A	33	36.7	42.20	1	53.3	7.5	5	CM	YM
SMAJ36(C)A	36	40.0	46.00	1	58.1	6.9	5	CP	YP
SMAJ40(C)A	40	44.4	51.10	1	64.5	6.2	5	CR	YR
SMAJ43(C)A	43	47.8	54.90	1	69.4	5.7	5	CT	YT
SMAJ45(C)A	45	50.0	57.50	1	72.7	5.5	5	CV	YV
SMAJ48(C)A	48	53.3	61.30	1	77.4	5.2	5	CX	YX
SMAJ51(C)A	51	56.7	65.20	1	82.4	4.9	5	CZ	YZ
SMAJ54(C)A	54	60.0	69.00	1	87.1	4.6	5	RE	ZE
SMAJ58(C)A	58	64.4	74.10	1	93.6	4.3	5	RG	ZG

PART NUMBER ADD C FOR BI- DIRECTIONAL	REVERSE STAND-OFF VOLTAGE	BREAKDOWN VOLTAGE VBR (V)	BREAKDOWN VOLTAGE VBR (V)	TEST CURRENT IT	MAXIMUM CLAMPING VOLTAGE	PEAK PULSE CURRENT	REVERSE LEAKAGE @ VRWM	MARKING CODE	
								See Note 1	VRWM (V)
SMAJ60(C)A	60	66.7	76.7	1	96.8	4.1	5	RK	ZK
SMAJ64(C)A	64	71.1	81.8	1	103	3.9	5	RM	ZM
SMAJ70(C)A	70	77.8	89.5	1	113	3.5	5	RP	ZP
SMAJ75(C)A	75	83.3	95.8	1	121	3.3	5	RR	ZR
SMAJ78(C)A	78	86.7	99.7	1	126	3.2	5	RT	ZT
SMAJ85(C)A	85	94.4	108.2	1	137	2.2	5	RV	ZV
SMAJ90(C)A	90	100	115.5	1	146	2.1	5	RX	ZX
SMAJ100(C)A	100	111	128.0	1	162	1.9	5	RZ	ZZ
SMAJ110(C)A	110	122	140.5	1	177	1.7	5	SE	VE
SMAJ120(C)A	120	133	153.0	1	193	1.6	5	VG	VG
SMAJ130(C)A	130	144	165.5	1	209	1.4	5	VK	VK
SMAJ150(C)A	150	167	192.5	1	243	1.2	5	VM	VM
SMAJ160(C)A	160	178	205.0	1	259	1.2	5	SP	VP
SMAJ170(C)A	170	189	217.5	1	275	1.09	5	SR	VR
SMAJ188(C)A	188	209	231.0	1	328	0.91	5	SS	VS
SMAJ200(C)A	200	224	247.0	1	332	0.89	5	SV	VV
SMAJ210(C)A	210	237	263.0	1	340	0.86	5	SW	VW
SMAJ220(C)A	220	246	272	1	352	0.8	5	SZ	VZ
SMAJ250(C)A	250	279	309	1	405	0.75	5	VM	VM
SMAJ300(C)A	300	335	371	1	486	0.7	5	TE	UE
SMAJ400(C)A	400	447	494	1	648	0.6	5	TK	UK
SMAJ440(C)A	440	492	543	1	713	0.6	5	TM	UM

I-V Curve Characteristics

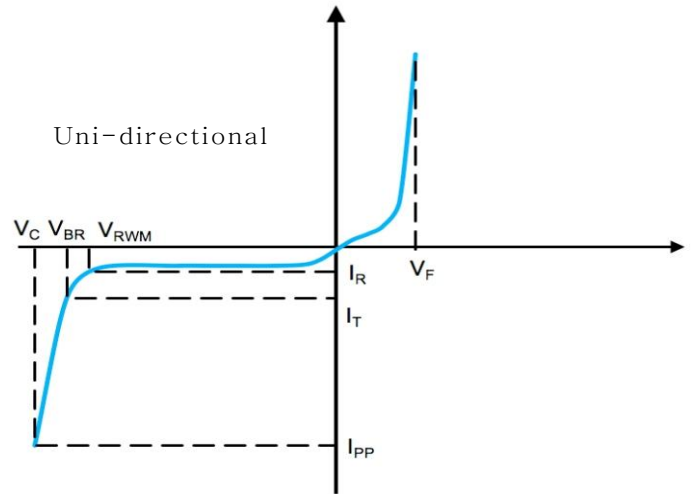
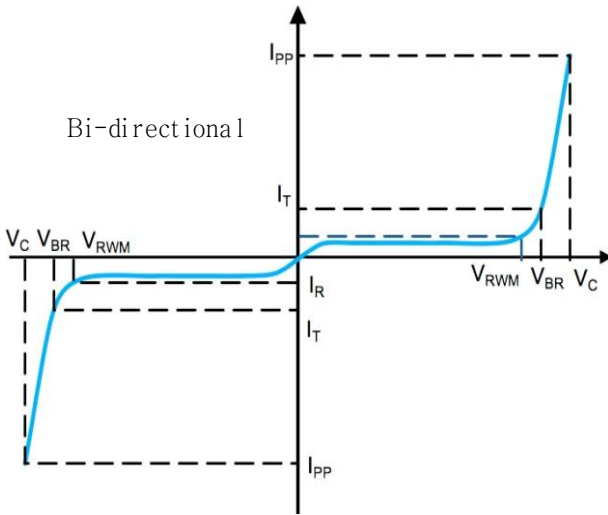

P_{PPM} Peak Pulse Power Dissipation - Max power dissipation

V_{RWM} Reverse Stand-off Voltage - Maximum voltage that can be applied to TVS without operation

V_{BR} Breakdown Voltage – Maximum voltage that flows though the TVS at a specified current (I_T)

V_C Clamping Voltage – Peak vltage measured across the TVS at a specified I_{PPM} (peak impulse current)

I_R Reverse Leakage Current – Current measured at V_R

V_F Forward Voltage Drop for Uni-directional

Soldering parameters

Reflow Condition		Pb-Free assembly (see as below)
Pre Heat	-Temperature Min ($T_{s(min)}$)	+150°C
	-Temperature Max($T_{s(max)}$)	+200°C
	-Time (Min to Max) (ts)	60-180 secs.
Average ramp up rate (Liquid us Temp (T_L) to peak)		3°C/sec. Max
$T_{s(max)}$ to T_L - Ramp-up Rate		3°C/sec. Max
Reflow	-Temperature(T_L)(Liquid us)	+217°C
	-Temperature(t_L)	60-150 secs.
Peak Temp (T_P)		+260(+0/-5)°C
Time within 5°C of actual Peak Temp (t_p)		30 secs. Max
Ramp-down Rate		6°C/sec. Max
Time 25°C to Peak Temp (T_P)		8 min. Max
Do not exceed		+260°C

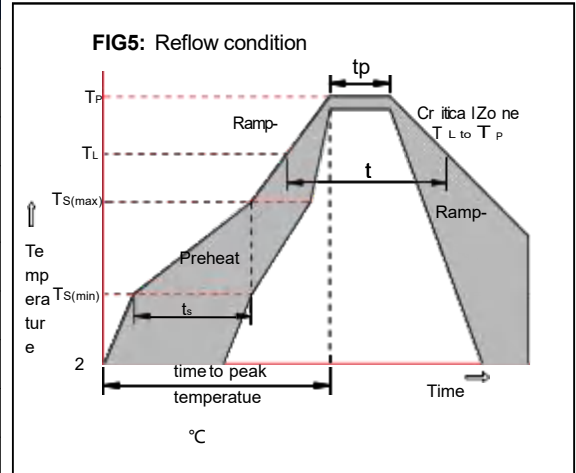

Package Dimensions & Suggested Pad Layout

SMA

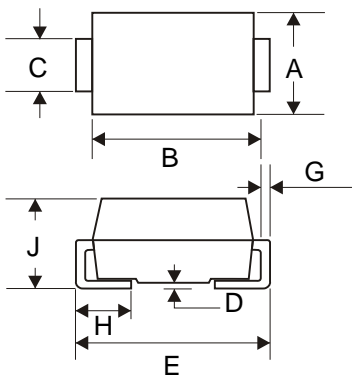

SMA		
Dim	Min	Max
A	2.40	2.79
B	3.99	4.50
C	1.32	1.47
D	-	0.20
E	4.93	5.28
G	0.15	0.31
H	0.76	1.52
J	1.98	2.29
All Dimensions in mm		

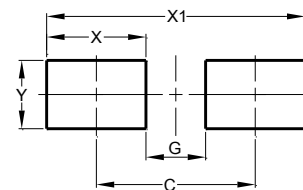

Dimensions	Value (in mm)
C	4.20
G	1.90
X	2.30
X1	6.50
Y	2.00

Tape & reel specification

Tape		Symbol	Dimension (mm)
		P0	4.00±0.20
		P1	4.00±0.20
		P2	2.00±0.20
		D0	1.60±0.20
		D1	1.60±0.20
		E	1.75±0.20
		F	5.50±0.15
		W	12.00±0.25
		A0	2.75±0.20
		B0	5.25±0.20
		K0	2.45±0.25
		T	0.20±0.10
		7" Reel	
		D3	55.0Min.
		D4	14.0±2.5
		W1	14.0±2.5
		Quantity: 2000PCS	
13" Reel		D5	330.0±5.0
		D6	73.0Min.
		D7	14.0±2.5
		W2	14.0±2.5
		Quantity: 5000PCS	